

**Thermostatic expansion valves
for ammonia**
Type TEA

Introduction

Thermostatic expansion valves regulate the injection of refrigerant liquid into evaporators. Injection is controlled by the refrigerant superheat.

Therefore the valves are especially suitable for liquid injection in „dry“ evaporators where the superheat at the evaporator outlet follows the evaporator load proportionally.



Features

- *Large temperature range: -50 to +30°C*
Can be used in both freezing and refrigeration systems.
- *Interchangeable orifice assemblies*
- *Interchangeable thermostatic element*
- *Rated capacities from 3.5 to 295 kW, 1 to 85 tons (TR).*
- *External superheat setting*
Can be matched to all evaporators to give optimum evaporator utilization.
- *Patented double contact bulb*
Fast and easy to install. Good temperature transfer from tube to bulb.

Materials

Valve housing made of GGG40.3

Gaskets are non asbestos

Technical data

- *Refrigerant*
R 717 (NH₃)
- *Evaporating temperature range*
D: -50 to 0°C
P: -20 to +30°C
- *Capillary tube length*
5 m
- *Connection for external pressure equalization*
¼ in. or Ø 6.5 / Ø 10 mm weld nipple.
An 8 mm self-cutting union can also be used.
- *Max. bulb temperature*
100°C
- *Max. working pressure*
PS/MWP = 19 bar
- *Max. test pressure*
28.5 bar

Identification

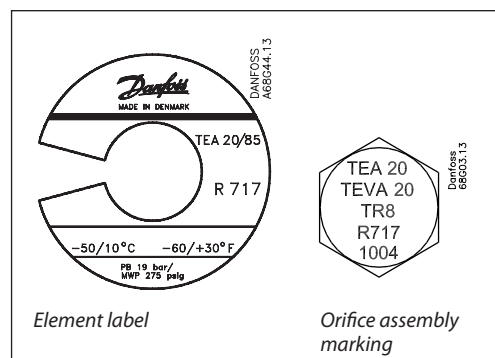

The thermostatic element has a white label attached to its top. The colour refers to the refrigerant for which the valve is designed: R 717 (NH₃).

The orifice assembly is marked with

- valve type (TEA 20)
- rated capacity (8 TR = 28 kW)
- refrigerant R 717 (NH₃)
- date stamp

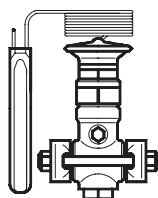
Ordering

Type and rated capacity in tons (TR)	Rated capacity ¹⁾ kW	Connection weld flanges		Code no.			
		Inlet in.	Outlet in.	Assembled valve	Separate strainer ²⁾	Separate orifice assembly	Separate thermostatic element

TEA 20, range: -50 to 0°C

TEA 20-1	3.5	1/2	1/2	068G6000	006-0042	068G2050	068G3250
TEA 20-2	7	1/2	1/2	068G6001		068G2051	
TEA 20-3	10.5	1/2	1/2	068G6002		068G2052	
TEA 20-5	17.5	1/2	1/2	068G6003		068G2053	
TEA 20-8	28	1/2	1/2	068G6004		068G2054	
TEA 20-12	42	1/2	1/2	068G6005		068G2055	
TEA 20-20	70	1/2	1/2	068G6006		068G2056	

TEA 20, range: -20 to +30°C

TEA 20-1	3.5	1/2	1/2	068G6137	006-0042	068G2050	068G3252
TEA 20-2	7	1/2	1/2	068G6133		068G2051	
TEA 20-3	10.5	1/2	1/2	068G6134		068G2052	
TEA 20-5	17.5	1/2	1/2	068G6138		068G2053	
TEA 20-8	28	1/2	1/2	068G6139		068G2054	
TEA 20-12	42	1/2	1/2	068G6140		068G2055	
TEA 20-20	70	1/2	1/2	068G6135		068G2056	

TEA 85, range: -50 to 0°C

TEA85-33	115	3/4	3/4	068G6007	006-0048	068G2057	068G3250
TEA 85-55	190	3/4	3/4	068G6008		068G2058	
TEA 85-85	295	3/4	3/4	068G6009		068G2059	

TEA 85, range: -20 to +30°C

TEA85-33	115	3/4	3/4	068G6141	006-0048	068G2057	068G3252
TEA 85-55	190	3/4	3/4	068G6142		068G2058	
TEA 85-85	295	3/4	3/4	068G6143		068G2059	

- ¹⁾ The rated capacity is the valve capacity at -15°C evaporating temperature and +32°C condensing temperature. The capacities are based on approx. 4 K subcooling ahead of valve.
- ²⁾ The filter is supplied with gaskets, bolts and nuts.

Note:

Subcooling of the liquid in front of the valve is essential for the function of the valve. Lack of subcooling will lead to malfunction of the valve, and increased wear on the orifice.

R 717 (NH₃)

Capacity in kW, range -50 to 0°C

Type and rated capacity in tons (TR)	Pressure drop across valve Δp bar								Pressure drop across valve Δp bar								
	2	4	6	8	10	12	14	16	2	4	6	8	10	12	14	16	
Evaporating temperature 0°C									Evaporating temperature -10°C								
TEA 20-1	2.1	2.9	3.3	3.7	4.1	4.3	4.5	4.8		2.7	3.0	3.3	3.6	4.0	4.2	4.4	
TEA 20-2	4.1	5.6	6.5	7.4	8.1	8.6	9.0	9.3		5.2	6.0	6.8	7.5	8.0	8.3	8.7	
TEA 20-3	5.9	8.3	9.9	11.2	12.1	13.0	13.5	14.0		7.8	9.1	10.1	11.2	12.0	12.6	13.0	
TEA 20-5	10.5	14.1	16.7	18.6	20.2	21.5	22.4	23.3		12.9	15.1	17.1	18.7	20.0	20.8	21.5	
TEA 20-8	15.7	22.1	26.2	29.7	32.0	34.3	36.1	37.2		20.9	24.4	27.9	30.2	31.7	33.1	34.3	
TEA 20-12	24.4	33.1	39.5	44.5	48.3	51.8	54.7	56.4		31.4	36.6	41.9	45.0	47.7	50.0	52.3	
TEA 20-20	40.7	55.0	66.3	74.4	80.9	86.1	90.2	93.7		51.8	60.5	68.6	75.1	79.1	83.3	85.6	
TEA 85-33	69.3	92.8	110	122	134	145	151	157		85.6	101	113	122	134	140	145	
TEA 85-55	114	151	180	204	221	238	250	256		145	169	186	204	221	233	244	
TEA 85-85	180	238	285	320	343	366	384	395		221	256	291	314	337	355	372	
Evaporating temperature -20°C									Evaporating temperature -30°C								
TEA 20-1		2.2	2.6	2.9	3.1	3.3	3.5	3.7			2.0	2.2	2.4	2.6	2.8	2.9	
TEA 20-2		4.3	4.9	5.6	6.2	6.6	6.9	7.1			4.1	4.5	4.9	5.2	5.5	5.6	
TEA 20-3		6.5	7.4	8.5	9.4	10.0	10.4	10.6			6.2	6.9	7.4	7.9	8.3	8.5	
TEA 20-5		11.0	12.9	14.4	15.6	16.5	17.2	17.7			10.1	11.3	12.3	13.1	13.7	14.3	
TEA 20-8		17.4	20.4	22.7	25.0	26.2	27.3	27.9			16.3	18.0	19.8	20.9	22.1	22.7	
TEA 20-12		25.6	30.8	34.9	37.2	39.5	41.9	43.0			25.0	27.9	30.2	31.4	32.6	33.7	
TEA 20-20		44.2	51.2	57.6	61.6	65.7	68.6	72.1			40.7	45.4	49.4	52.3	54.7	57.0	
TEA 85-33		72.1	84.9	94.9	103	109	114	116			68.6	75.0	80.9	85.6	90.2	94.2	
TEA 85-55		116	145	163	174	180	186	192			114	128	140	145	151	157	
TEA 85-85		180	221	244	267	279	291	302			174	192	209	221	233	244	
Evaporating temperature -40°C									Evaporating temperature -50°C								
TEA 20-1			1.3	1.7	1.9	2.0	2.2	2.3			1.2	1.3	1.4	1.5	1.6	1.7	
TEA 20-2			3.1	3.5	3.8	4.0	4.2	4.4			2.4	2.7	2.8	3.0	3.1	3.3	
TEA 20-3			4.8	5.2	5.7	6.0	6.4	6.6			3.7	4.1	4.3	4.5	4.8	5.0	
TEA 20-5			8.0	8.7	9.4	10.1	10.6	11.0			6.0	6.6	7.1	7.6	7.9	8.3	
TEA 20-8			12.8	14.0	15.1	16.3	16.9	17.4			9.3	10.5	11.0	11.6	12.2	12.8	
TEA 20-12			19.2	20.9	22.7	24.4	26.2	27.3			14.5	15.7	16.9	18.0	19.2	20.4	
TEA 20-20			32.0	35.5	38.4	40.7	43.0	44.8			24.4	26.2	27.9	29.7	31.4	32.6	
TEA 85-33			52.3	58.2	61.6	65.1	68.6	72.1			39.5	43.6	46.5	49.4	51.8	54.1	
TEA 85-55			86.8	96.5	104	110	116	122			66.3	72.1	77.8	81.9	86.1	89.6	
TEA 85-85			134	151	163	174	180	186			104	113	122	128	134	140	

1) Subcooling Δt = 4K ahead of the valve.

Example

Given:
 Refrigerant = R 717 (NH₃)
 Evaporator capacity Q_e = 265 kW (75.3 TR)
 Evaporating temperature t_e = -20°C
 (~p_e = 1.9 bar)
 Condensing temperature t_c = +32°C
 (~p_c = 12.4 bar)
 Subcooling Δt = 4K
 If the pressure drop Δp₁ across pipelines, etc. is calculated, for example, as 0.5 bar, the effective pressure drop across the thermostatic valve becomes
 $\Delta p = p_c - p_e - p_1$
 $\Delta p = 12.4 - 1.9 - 0.5 = 10 \text{ bar.}$

Now, from the capacity table at an evaporating temperature t_e = -20°C and Δp = 10 bar, the capacity is 267 kW.

The column on the far left of this point gives the valve designation: TEA 85-85.

The ordering table gives the code no. for TEA 85-85: 068G6009.

Generally, the maximum capacity of a valve is approx. 20% higher than the value given in the table.

If a different capacity is subsequently required, a separate orifice assembly with a suitable rated capacity can be ordered to replace the one fitted in the installed valve.

R 717 (NH₃)

Capacity in kW, range -20 to +30°C

Type and rated capacity in tons (TR)	Pressure drop across valve Δp bar								Pressure drop across valve Δp bar								
	2	4	6	8	10	12	14	16	2	4	6	8	10	12	14	16	
Evaporating temperature +30°C									Evaporating temperature +20°C								
TEA 20-1	2.6	3.4	3.9	4.3	4.6	4.8	5.0	5.2	2.7	3.4	3.9	4.2	4.5	4.8	4.9	5.1	
TEA 20-2	4.7	6.5	7.5	8.1	8.7	9.2	9.6	9.9	4.9	6.6	7.5	8.1	8.7	9.1	9.5	9.9	
TEA 20-3	5.6	7.8	9.3	10.4	11.4	12.2	12.9	13.5	5.9	8.0	9.6	10.8	11.7	12.5	13.2	13.9	
TEA 20-5	11.6	16.0	19.0	20.9	22.2	23.4	24.5	25.4	12.1	16.5	19.3	20.9	22.2	23.4	24.4	25.4	
TEA 20-8	19.9	27.3	31.3	34.4	36.6	38.6	40.3	41.8	20.7	28.1	31.5	34.2	36.5	38.4	40.1	41.6	
TEA 20-12	29.1	39.6	45.3	49.2	52.2	55.2	57.7	59.8	30.2	40.2	45.0	48.8	52.0	54.8	57.2	59.3	
TEA 20-20	42.9	66.2	74.6	81.1	86.4	90.9	94.8	98.3	50.7	65.9	73.8	80.0	85.2	89.7	93.7	97.2	
TEA 85-33	83.0	106	122	133	143	150	158	164	85.0	106	120	132	141	149	156	163	
TEA 85-55	134	179	205	222	236	248	259	268	137	181	202	219	233	245	256	265	
TEA 85-85	196	257	297	328	353	374	392	408	200	258	296	326	351	372	390	406	
Evaporating temperature +10°C									Evaporating temperature 0°C								
TEA 20-1	2.6	3.3	3.8	4.2	4.4	4.7	4.9	5.0	2.6	3.2	3.7	4.1	4.3	4.6	4.8	5.0	
TEA 20-2	5.1	6.6	7.4	8.0	8.6	9.0	9.5	9.9	5.2	6.4	7.2	7.9	8.4	8.9	9.4	9.7	
TEA 20-3	6.1	8.3	9.8	11.0	12.0	12.8	13.5	14.1	6.3	8.5	10.0	11.2	12.1	12.9	13.6	14.2	
TEA 20-5	12.5	17.0	19.1	20.7	22.0	23.2	24.3	25.2	12.9	16.8	18.7	20.3	21.7	22.9	23.9	24.9	
TEA 20-8	21.3	27.8	31.1	33.7	36.0	37.9	39.6	41.2	21.8	27.1	30.3	33.0	35.2	37.2	39.0	40.5	
TEA 20-12	30.9	39.5	44.2	47.9	51.1	53.9	56.3	58.5	31.4	38.4	42.9	46.7	49.9	52.7	55.2	57.4	
TEA 20-20	51.6	64.5	72.1	78.2	83.4	88.0	92.0	95.6	51.7	62.3	69.8	76.0	81.3	85.9	90.0	93.7	
TEA 85-33	84.0	104	118	129	139	147	153	160	82.0	101	114	126	135	143	151	157	
TEA 85-55	140	178	198	214	228	241	251	261	139	172	192	208	223	235	246	256	
TEA 85-85	200	255	292	321	346	367	385	401	196	248	285	314	339	360	378	395	
Evaporating temperature -10°C									Evaporating temperature -20°C								
TEA 20-1		3.1	3.6	3.9	4.2	4.4	4.6	4.8		2.9	3.2	3.5	3.8	4.0	4.2	4.4	
TEA 20-2		6.1	6.9	7.5	8.1	8.6	9.0	9.4		5.4	6.2	6.8	7.3	7.8	8.2	8.6	
TEA 20-3		8.5	10.0	11.2	12.1	12.9	13.5	14.1		8.4	9.9	11.0	11.9	12.5	13.0	13.4	
TEA 20-5		15.6	17.5	19.1	20.4	21.6	22.7	23.6		13.6	15.4	17.0	18.3	19.4	20.4	21.3	
TEA 20-8		24.7	27.8	30.4	32.6	34.6	36.3	37.8		21.0	24.0	26.5	28.6	30.4	32.0	33.4	
TEA 20-12		36.9	41.5	45.3	48.6	51.5	54.0	56.3		32.2	36.7	40.4	43.5	46.3	48.7	50.9	
TEA 20-20		59.7	67.3	73.6	79.0	83.7	87.9	91.7		56.9	64.6	71.0	76.6	81.4	85.6	89.5	
TEA 85-33		97.0	111	122	131	140	147	154		92.0	107	118	128	136	144	150	
TEA 85-55		165	185	202	216	229	241	251		158	178	196	211	224	235	245	
TEA 85-85		239	276	306	331	352	371	388		230	267	297	323	345	364	381	

1) Subcooling Δt = 4K ahead of the valve.

**Design/
Function**

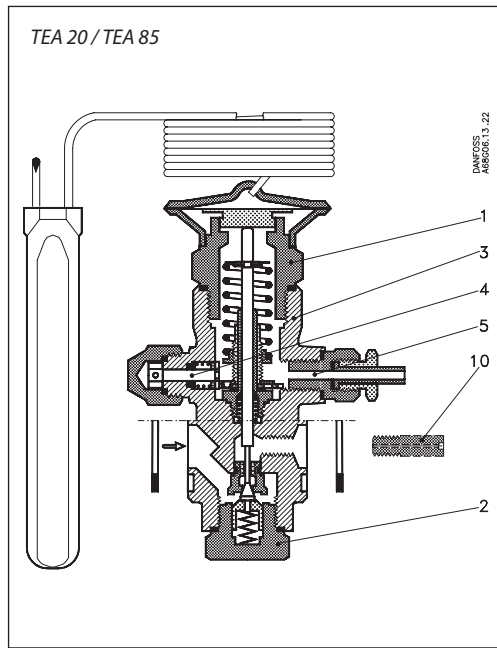

1. Thermostatic element (diaphragm)
2. Orifice assembly
3. Valve body
4. Superheat setting spindle (see „Instructions“)
5. Ext. pressure equalizing connection
10. Separate outlet orifice (for TEA 20-1 only)

General

TEA is equipped with interchangeable orifice assembly and thermostatic element. TEA is built up of three interchangeable main components:

- Thermostatic element (1)
- Orifice assembly (2)
- Valve body (3), with flange connections

The valve has external equalization. A separate outlet orifice assembly (10) is for use with TEA 20-1 (3.5 kW) only.

The double contact bulb gives fast and precise reaction to temperature changes in the evaporator suction line, even with much reduced evaporator load. It also makes fitting the bulb quick and easy.

The valves are able to withstand the effects that normally occur with hot gas defrosting.

The movement of the setting spindle is transferred by a gearwheel mechanism that ensures smooth superheat setting.

The throttling section of the orifice assembly has a long operating life, the valve cone and seat being made of a special alloy steel with particularly good wear qualities.

Note:

The TEA is not able to close completely tight. Consequently a solenoid valve is needed to shut off liquid supply when systems stops.

Dimensions and weights

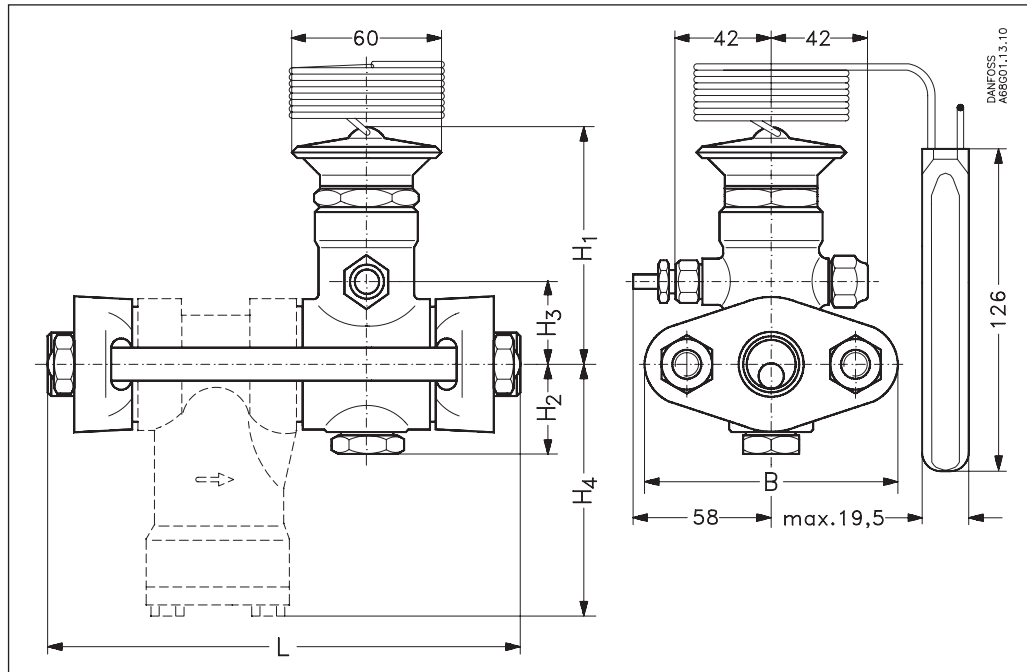

Type	H ₁ mm	H ₂ mm	H ₃ mm	H ₄ mm	L		B mm	Weight	
					Excl. strainer mm	Incl. strainer mm		Excl. strainer kg	Incl. strainer kg
TEA 20	94	38	25	96	110	164	80	2.1	3.0
TEA 85	104	37	35	106	125	199	95	3.0	4.5

