

Technical leaflet

Solenoid valves

Type EVRA 3 → 40 and EVRAT 10 → 20

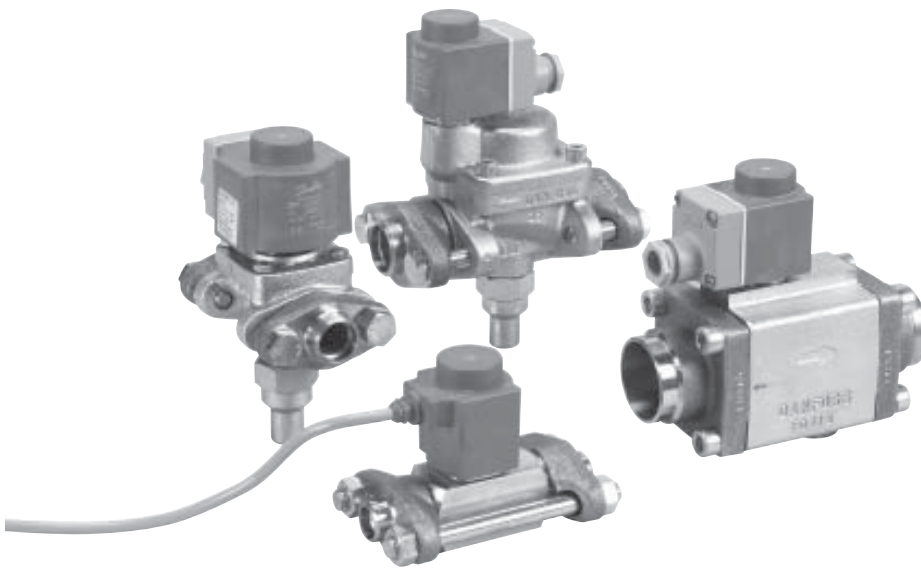

Contents**Page**

Introduction	4
Approvals	4
Technical data	4
Ordering	5
Flanges	6-7
Liquid capacity	8
Suction vapour capacity	9-10
Hotgas capacity	11-16
Design/ Function	17
Material specification	18
Dimensions and weight	19-20

Introduction

EVRA is a direct or servo operated solenoid valve for liquid, suction and hot gas lines with ammonia or fluorinated refrigerants.

EVRA valves are supplied complete or as separate components, i.e. valve body, coil and flanges can be ordered separately.

EVRAT is an assisted lift, servo operated solenoid valve for liquid, suction and hot gas lines with ammonia and fluorinated refrigerants. EVRAT is specially designed to open - and stay open - at a pressure drop of 0 bar. The EVRAT solenoid valve is thus suitable for use in all plant where the required opening differential pressure is 0 bar.

EVRAT is available as components, i.e. valve body, flanges and coil must be ordered separately.

EVRAT 10, 15 and 20 all have spindle for manual operation.

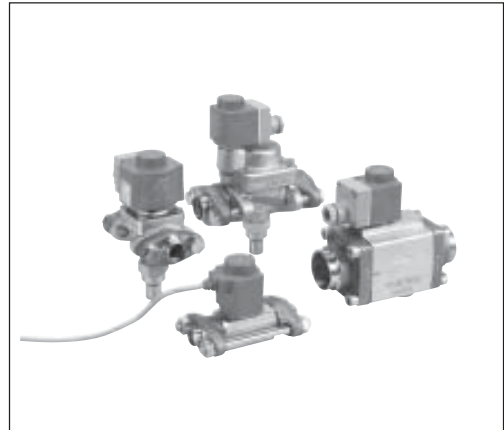

Approval

- DNV, Det Norske Veritas, Norway
- P Polski Rejestr Statków, Poland
- MRS, Maritime Register of Shipping, Russia
- Pressure Equipment Directive (PED) (97/23/EC)(EVRA 32 and 40 CE marked according to PED)
- UL listed with GP coils

Technical data

Refrigerants
R 717 (NH₃), R 22, R 134a, R 404A, R 12, R 502 etc.

Ambient temperature and enclosure for coil
See "Coils for solenoid valves", RD.3J.E2.02.

Temperature of medium
-40 → +105°C.
Max. 130°C during defrosting.

Type	Opening differential pressure with standard coil (Δp bar)				Max. working Temperature of medium °C	pressure PB bar	k_v -value m ³ /h
	Min.	Max. (= MOPD) liquid ²⁾					
		10 W a.c.	12 W a.c.	20 W d.c.			
EVRA 3	0.00	21	25	14	-40 → 105	28	0.23
EVRA 10	0.05	21	25	18	-40 → 105	28	1.5
EVRAT 10	0.00	14	21	16	-40 → 105	28	1.5
EVRA 15	0.05	21	25	18	-40 → 105	28	2.7
EVRAT 15	0.00	14	21	16	-40 → 105	28	2.7
EVRA 20	0.05	21	25	13	-40 → 105	28	4.5
EVRAT 20	0.00	14	21	13	-40 → 105	28	4.5
EVRA 25	0.20	21	25	14	-40 → 105	28	10.0
EVRA 32	0.20	21	25	14	-40 → 105	28	16.0
EVRA 40	0.20	21	25	14	-40 → 105	28	25.0

1) The k_v value is the water flow in m³/h at a pressure drop across valve of 1 bar, $\rho = 1000 \text{ kg/m}^3$.
2) MOPD for media in gas form is approx. 1 bar greater.

Type	Rated capacity ¹⁾ [kW]											
	Liquid				Suction vapour				Hot gas			
	R717	R22	R134a	R404A	R717	R22	R134a	R404A	R717	R22	R134a	R404A
EVRA3	21.8	4.6	4.3	3.2					6.5	2.1	1.7	1.7
EVRA/T 10	142.0	30.2	27.8	21.1	9.0	3.4	2.5	3.1	42.6	13.9	11.0	11.3
EVRA/T 15	256.0	54.4	50.1	38.0	16.1	6.2	4.4	5.5	76.7	24.9	19.8	20.3
EVRA/T 20	426.0	90.6	83.5	63.3	26.9	10.3	7.3	9.2	128.0	41.5	32.9	33.9
EVRA 25	947.0	201.0	186.0	141.0	59.7	22.8	16.3	20.4	284.0	92.3	73.2	75.3
EVRA 32	1515.0	322.0	297.0	225.0	95.5	36.5	26.1	32.6	454.0	148.0	117.0	120.0
EVRA 40	2368.0	503.0	464.0	351.0	149.0	57.0	40.8	51.0	710.0	231.0	183.0	188.0

1) Rated liquid and suction vapour capacity is based on evaporating temperature $t_e = -10^\circ\text{C}$, liquid temperature ahead of valve $t_l = +25^\circ\text{C}$, and pressure drop across valve $\Delta p = 0.15 \text{ bar}$.

Rated hot gas capacity is based on condensing temperature $t_c = +40^\circ\text{C}$, pressure drop across valve $\Delta p = 0.8 \text{ bar}$, hot gas temperature $t_h = +65^\circ\text{C}$, and subcooling of refrigerant $\Delta t_{\text{sub}} = 4 \text{ K}$.

Ordering

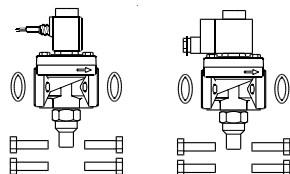

Complete valves without flanges

Type	Connection	Code no. ¹⁾	
		10 W coil with 1 m cable	10 W coil with terminal box

Valves without manual operation

Type	Connection	Code no.	Code no.
EVRA 3	See table <i>Flange set</i>	032F3102	032F3103
EVRA 10		032F6207	032F6208

Valves with manual operation

Type	Connection	Code no.	Code no.
EVRA 10	See table <i>Flange set</i>	032F6212	032F6213
EVRA 15		032F6217	032F6218
EVRA 20		032F6222	032F6223

1) Valve body with gaskets, bolts and 10 W a.c. coil. Please specify code no., voltage and frequency. Voltage and

frequency can also be given in the form of an appendix number, see table "Appendix numbers", under EVR.

Separate valve bodies

Type	Connection	Required coil type	Code no.
------	------------	--------------------	----------

Valves with manual operation

Type	Connection	Required coil type	Code no.
EVRA 10	See table <i>Flange set</i>	a.c./d.c.	032F6210
EVRAT 10		a.c./d.c.	032F6214
EVRA 15		a.c./d.c.	032F6215
EVRAT 15		a.c./d.c.	032F6216
EVRA 20		a.c.	032F6220
EVRAT 20		d.c.	032F6221
EVRA 20		a.c./d.c.	032F6219
EVRA 25		a.c./d.c.	032F6225

a.c./d.c.
a.c./d.c.
a.c./d.c.
a.c./d.c.
a.c.
d.c.
a.c./d.c.
a.c./d.c.

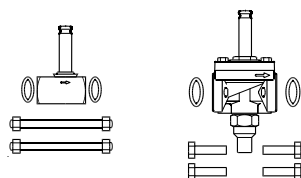

Valves without manual operation

Type	Connection	Required coil type	Code no.
EVRA 3	See table <i>Flange set</i>	a.c./d.c.	032F3050
EVRA 10		a.c./d.c.	032F6211
EVRA 25		a.c./d.c.	032F6226

Separate valve bodies with butt weld connections

Type	Butt weld connection		Code no.
	DIN	ANSI	

Valves with manual operation

Type	Connection	Required coil type	Code no.
EVRA 32	1 ¼ in.		042H1126
EVRA 32	1 ½ in.		042H1131
EVRA 32		1 ¼ in.	042H1140
EVRA 32		1 ½ in.	042H1141
EVRA 40	1 ½ in.		042H1128
EVRA 40	2 in.		042H1132
EVRA 40		1 ½ in.	042H1142
EVRA 40		2 in.	042H1143



Coils

See "Coils for solenoid valves", RD.3J.E2.02.

Accessories

Strainer FA for direct mounting, see "FA".

Flanges,

see the following pages.

Example

EVRA 15 complete valve with terminal box, 220 V, 50 Hz, code no. **032F6218**
+ ¾ in. weld flange set, code no. **027N1120**.

Example

EVRA 15 valve body with manual operation, code no. **032F6215**
+ ¾ in. weld flange set, code no. **027N1120**
+ coil with terminal box, 220 V, 50 Hz, code no. **018F6701**

Ordering (continued)

Tongue/ tongue flange sets version 1.3

Used for:
EVRA 3, EVRA/T 10, EVRA/T 15
 Each code no. includes two flanges

Separate flange gaskets,
 ID 22 x OD 32 x 1.0 mm
 (ID 0.866 x OD 1.260 x 0.039 in.):
 Code no. 020-2133 (40 stk.) must be ordered separately

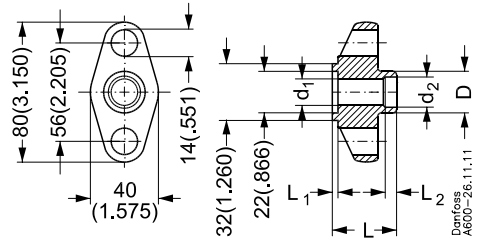

Butt welding DIN (2448)
 Tongue flange sets

Connection		D	D	d ₁	d ₁	d ₂	d ₂	L	L	L ₁	L ₁	L ₂	L ₂	Codeno.
mm	in.	mm	in.	mm	in.	mm	in.	mm	in.	mm	in.	mm	in.	
10	3/8	18	0.709	10	0.394	14	0.551	32.5	1.280	3	0.118	6	0.236	027N1112
15	1/2	22	0.866	14	0.551	17	0.669	32.5	1.280	3	0.118	6	0.236	027N1115
20	3/4	27	1.063	19	0.748	22	0.866	32.5	1.280	3	0.118	6	0.236	027N1120

Butt welding ANSI B 36.10
 Tongue flange sets

Connection		D	D	d ₁	d ₁	d ₂	d ₂	L	L	L ₁	L ₁	L ₂	L ₂	Codeno.
mm	in.	mm	in.	mm	in.	mm	in.	mm	in.	mm	in.	mm	in.	
10	3/8	17.1	0.673	10.7	0.421	10.7	0.421	32.5	1.280	3	0.118	6	0.236	027N2020
15	1/2	21.3	0.839	13.9	0.547	13.9	0.547	32.5	1.280	3	0.118	6	0.236	027N2021
20	3/4	26.9	1.059	18.9	0.744	18.9	0.744	32.5	1.280	3	0.118	6	0.236	027N2022

Socket welding ANSI (B 16.11)
 Tongue flange sets

Connection		D	D	d ₁	d ₁	d ₂	d ₂	L	L	L ₁	L ₁	L ₂	L ₂	Codeno.
mm	in.	mm	in.	mm	in.	mm	in.	mm	in.	mm	in.	mm	in.	
10	3/8	26	1.024	12.5	0.492	17.8	0.701	32.5	1.280	3	0.118	10	0.394	027N2010
15	1/2	31.6	1.244	15.8	0.622	22	0.866	32.5	1.280	3	0.118	10	0.394	027N2011

FPT internal thread, NPT (ANSI / ASME B 1.20.1)
 Tongue flange sets

Connection		D	D	d ₁	d ₁	d ₂	d ₂	L	L	L ₁	L ₁	L ₂	L ₂	Codeno.
mm	in.	mm	in.	mm	in.	mm	in.	mm	in.	mm	in.	mm	in.	
10	3/8	26	1.024	14.3	0.563	3/8"-18 NPT	3/8"-18 NPT	32.5	1.477	3	0.118			027G1005
15	1/2	31.6	1.244	17.8	0.701	1/2"-14 NPT	1/2"-14 NPT	32.5	1.280	3	0.118			027G1006

Solder DIN (2856)
 Tongue flange sets

Connection		D	D	d ₁	d ₁	d ₂	d ₂	L	L	L ₁	L ₁	L ₂	L ₂	Codeno.
mm	in.	mm	in.	mm	in.	mm	in.	mm	in.	mm	in.	mm	in.	
16		21	0.827	13	0.512	16	0.630	29.5	2.122	3	0.118	15	0.591	027L1116
22		27	1.063	19	0.748	22.1	0.869	29.5	1.161	3	0.118	22	0.866	027L1122

Solder ANSI B 16.22
 Tongue flange sets

Connection		D	D	d ₁	d ₁	d ₂	d ₂	L	L	L ₁	L ₁	L ₂	L ₂	Codeno.
	in.	mm	in.	mm	in.	mm	in.	mm	in.	mm	in.	mm	in.	
	5/8	21	0.827	13	0.512	15.9	0.626	29.5	1.161	3	0.118	20.5	0.807	027L1117
	7/8	27	1.063	19	0.748	22.2	0.874	29.5	1.161	3	0.118	22	0.866	027L1123

Ordering (continued)

**Tongue/ tongue flange sets
version 3**

Used for
EVRA/T 20, EVRA 25
Each code no. includes two flanges.

Separate flange gaskets,
ID 29 x OD 39 x 1.5 mm
(ID 1.142 x OD 1.535 x 0.059 in.):

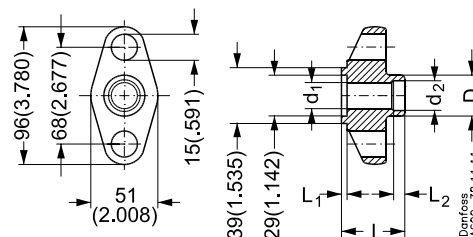
**Butt welding DIN (2448)
Tongue flange sets**

Connection		D	D	d ₁	d ₁	d ₂	d ₂	L	L	L ₁	L ₁	L ₂	L ₂	Codeno.
mm	in.	mm	in.	mm	in.	mm	in.	mm	in.	mm	in.	mm	in.	
20	3/4	27	1.063	19	0.748	22	0.866	35	1.378	3	0.118	6	0.236	027N1220
25	1	34	1.339	26	1.024	28	1.102	37.5	1.476	3	0.118	6	0.236	027N1225
32	1 1/4	43	1.693	26	1.024	37	1.457	37.5	1.476	3	0.118	6	0.236	027N1230

**Butt welding ANSI B 36.10
Tongue flange sets**

Connection		D	D	d ₁	d ₁	d ₂	d ₂	L	L	L ₁	L ₁	L ₂	L ₂	Codeno.
mm	in.	mm	in.	mm	in.	mm	in.	mm	in.	mm	in.	mm	in.	
20	3/4	26.9	1.059	18.9	0.744	18.9	0.744	33	1.299	3	0.118	6	0.236	027N3031
25	1	33.7	1.327	24.5	0.965	24.5	0.965	37.5	1.476	3	0.118	6	0.236	027N3032
32	1 1/4	42.4	1.669	26	1.024	32.6	1.283	37.5	1.476	3	0.118	6	0.236	027N3033

**Socket welding ANSI (B 16.11)
Tongue flange sets**

Connection		D	D	d ₁	d ₁	d ₂	d ₂	L	L	L ₁	L ₁	L ₂	L ₂	Codeno.
mm	in.	mm	in.	mm	in.	mm	in.	mm	in.	mm	in.	mm	in.	
20	3/4	37.4	1.472	21	0.827	27.4	1.079	33	1.299	3	0.118	13	0.512	027N2001
25	1	45.6	1.795	26.6	1.047	34.1	1.343	33	1.299	3	0.118	13	0.512	027N2002

**FPT internal thread, NPT (ANSI / ASME B 1.20.1)
Tongue flange sets**

Connection		D	D	d ₁	d ₁	d ₂	d ₂	L	L	L ₁	L ₁	L ₂	L ₂	Codeno.
mm	in.	mm	in.	mm	in.	mm	in.	mm	in.	mm	in.	mm	in.	
20	3/4	37.4	1.472	23	0.906	3/4"-14 NPT	3/4"-14 NPT	33	1.299	3	0.118	3	0.118	027G1001
25	1	45.6	1.795	29	1.142	1"-11.5 NPT	1"-11.5 NPT	33	1.299	3	0.118	3	0.118	027G1002

**Soldering DIN (2856)
Tongue flange sets**

Connection		D	D	d ₁	d ₁	d ₂	d ₂	L	L	L ₁	L ₁	L ₂	L ₂	Codeno.
mm	in.	mm	in.	mm	in.	mm	in.	mm	in.	mm	in.	mm	in.	
22		34	1.338	19	0.748	22	0.866	32	1.260	4	0.157	16.5	0.650	027L1222
28		34	1.338	26	1.024	28	1.102	34	1.338	4	0.157	26	1.024	027L1228

**Soldering ANSI B 16.22
Tongue flange sets**

Connection		D	D	d ₁	d ₁	d ₂	d ₂	L	L	L ₁	L ₁	L ₂	L ₂	Codeno.
	in.	mm	in.	mm	in.	mm	in.	mm	in.	mm	in.	mm	in.	
	7/8	34	1.338	19	0.748	22.2	0.874	32	1.260	4	0.157	16.5	0.650	027L1223
	1 1/8	34	1.338	26	1.024	28.6	1.126	34	1.338	4	0.157	26	1.024	027L1229

Capacity

 Liquid capacity Q_l kW

Type	Liquid capacity Q_e kW at pressure drop across valve Δp bar				
	0.1	0.2	0.3	0.4	0.5

R 717 (NH₃)

EVRA 3	17.8	25.1	30.8	35.6	39.8
EVRA/T 10	116.0	164.0	201.0	232.0	259.0
EVRA/T 15	209.0	295.0	362.0	418.0	467.0
EVRA/T 20	348.0	492.0	603.0	696.0	778.0
EVRA 25	773.0	1093.0	1340.0	1547.0	1729.0
EVRA 32	1237.0	1749.0	2144.0	2475.0	2766.0
EVRA 40	1933.0	2734.0	3349.0	3867.0	4322.0

R 22

EVRA 3	3.8	5.3	6.6	7.6	8.5
EVRA/T 10	24.7	34.9	42.7	49.3	55.1
EVRA/T 15	44.4	62.8	76.9	88.8	99.2
EVRA/T 20	73.9	105.0	128.0	148.0	165.0
EVRA 25	165.0	232.0	285.0	329.0	368.0
EVRA 32	263.0	372.0	455.0	526.0	588.0
EVRA 40	411.0	581.0	712.0	822.0	919.0

R 134a

EVRA 3	3.5	4.9	6.0	7.0	7.8
EVRA/T 10	22.7	32.2	39.4	45.5	50.8
EVRA/T 15	40.9	57.9	70.9	81.8	91.5
EVRA/T 20	68.2	96.5	118.0	136.0	153.0
EVRA 25	152.0	214.0	263.0	303.0	339.0
EVRA 32	243.0	343.0	420.0	485.0	542.0
EVRA 40	379.0	536.0	656.0	758.0	847.0

R 404A

EVRA 3	2.6	3.7	4.6	5.3	5.9
EVRA/T 10	17.2	24.3	29.8	34.4	38.5
EVRA/T 15	31.0	43.8	53.7	62.0	69.3
EVRA/T 20	51.7	73.0	89.5	103.0	116.0
EVRA 25	115.0	162.0	199.0	230.0	257.0
EVRA 32	184.0	260.0	318.0	367.0	411.0
EVRA 40	287.0	406.0	497.0	574.0	642.0

Capacities are based on liquid temperature $t_l = +25^\circ\text{C}$ ahead of valve, evaporating temperature $t_e = -10^\circ\text{C}$, and superheat 0 K.

Correction factors

When sizing valves, the plant capacity must be multiplied by a correction factor depending on liquid temperature t_l ahead of valve/evaporator.

When the corrected capacity is known, the selection can be made from the table.

t_l °C	-10	0	+10	+20	+25	+30	+40	+50
R 717 (NH ₃)	0.84	0.88	0.92	0.97	1.0	1.03	1.09	1.16
R 22, R 134a	0.76	0.81	0.88	0.96	1.0	1.05	1.16	1.31
R 404A	0.70	0.76	0.84	0.94	1.0	1.07	1.24	1.47

Capacity
(continued)

Suction vapour capacity Q_e kW

Type	Pressure drop across valve Δp bar	Suction vapour capacity Q_e kW at evaporating temperature t_e °C					
		-40	-30	-20	-10	0	+10

R 717 (NH₃)

EVRAT 10	0.1	3.4	4.5	5.9	7.3	8.9	10.6
	0.15	4.0	5.4	7.0	9.0	10.9	13.0
	0.2	4.5	6.1	7.9	10.0	12.6	15.0
EVRAT 15	0.1	6.1	8.1	10.7	13.2	16.0	19.1
	0.15	7.2	9.7	12.5	16.1	19.6	23.4
	0.2	8.0	11.0	14.2	18.0	22.6	27.0
EVRAT 20	0.1	10.2	13.5	17.8	21.9	26.6	31.9
	0.15	12.1	16.1	20.9	26.9	32.6	39.0
	0.2	13.4	18.3	23.7	29.9	37.7	45.1
EVRA 25	0.1	22.6	30.0	39.5	48.7	59.2	70.8
	0.15	26.7	35.9	46.3	59.7	72.5	86.7
	0.2	29.8	40.5	52.7	66.4	83.7	100.0
EVRA 32	0.1	36.2	47.8	63.2	77.9	94.7	113.0
	0.15	42.7	57.4	74.1	95.5	116.0	139.0
	0.2	47.7	64.8	84.3	106.0	134.0	160.0
EVRA 40	0.1	56.5	74.8	98.8	122.0	148.0	177.0
	0.15	66.8	89.8	116.0	149.0	181.0	217.0
	0.2	74.5	101.0	132.0	166.0	209.0	251.0

R 22

EVRAT 10	0.1	1.4	1.8	2.3	2.8	3.4	4.0
	0.15	1.6	2.1	2.7	3.4	4.1	4.9
	0.2	1.8	2.4	3.1	3.8	4.8	5.6
EVRAT 15	0.1	2.5	3.2	4.1	5.0	6.1	7.2
	0.15	2.9	3.8	4.8	6.2	7.4	8.8
	0.2	3.3	4.3	5.5	6.8	8.6	10.2
EVRAT 20	0.1	4.1	5.3	6.8	8.4	10.1	12.0
	0.15	4.9	6.4	8.1	10.3	12.3	14.7
	0.2	5.5	7.2	9.2	11.4	14.3	16.9
EVRA 25	0.1	9.1	11.8	15.2	18.6	22.4	26.6
	0.15	10.9	14.2	17.9	22.8	27.4	32.6
	0.2	12.2	16.1	20.4	25.3	31.7	37.6
EVRA 32	0.1	14.6	18.9	24.3	29.8	35.8	42.6
	0.15	17.4	22.7	28.8	36.5	43.8	52.2
	0.2	19.6	25.7	32.6	40.5	50.7	60.2
EVRA 40	0.1	22.8	29.5	38.1	46.5	56.0	66.5
	0.15	27.2	35.4	45.0	57.0	68.6	81.5
	0.2	30.5	40.2	51.0	63.3	79.2	94.0

Capacities are based on liquid temperature $t_l = +25^\circ\text{C}$ ahead of evaporator. The table values refer to the evaporator capacity and are given as a function of evaporating temperature t_e and pressure drop Δp across valve. Capacities are based on dry, saturated vapour ahead of valve. During operation with superheated vapour ahead of valve, the capacities are reduced by 4% for each 10 K superheat.

Correction factors

When sizing valves, the evaporator capacity must be multiplied by a correction factor depending on liquid temperature t_l ahead of expansion valve. When the corrected capacity is known, the selection can be made from the table.

t_l °C	-10	0	+10	+20	+25	+30	+40	+50
R 717 (NH ₃)	0.84	0.88	0.92	0.97	1.0	1.03	1.09	1.16
R 22	0.76	0.81	0.88	0.96	1.0	1.05	1.16	1.31

Capacity
(continued)

Suction vapour capacity Q_e kW

Type	Pressure drop across valve Δp bar	Suction vapour capacity Q_e kW at evaporating temperature t_e °C					
		-40	-30	-20	-10	0	+10

R 134a

EVRAT 10	0.1	0.87	1.2	1.6	2.1	2.6	3.2
	0.15	0.99	1.4	1.9	2.4	3.2	3.9
	0.2	1.1	1.6	2.1	2.8	3.5	4.5
EVRAT 15	0.1	1.6	2.1	2.8	3.8	4.7	5.7
	0.15	1.8	2.5	3.4	4.4	5.7	7.0
	0.2	2.0	2.8	3.8	5.0	6.3	8.1
EVRAT 20	0.1	2.6	3.6	4.7	6.3	7.8	9.5
	0.15	3.0	4.2	5.6	7.3	9.5	11.7
	0.2	3.3	4.7	6.4	8.3	10.5	13.5
EVRA 25	0.1	5.8	7.9	10.5	13.9	17.2	21.1
	0.15	6.6	9.3	12.5	16.3	21.1	25.9
	0.2	7.3	10.4	14.1	18.5	23.4	29.9
EVRA 32	0.1	9.3	12.6	16.8	22.2	27.7	33.8
	0.15	10.6	14.9	20.0	26.1	33.8	41.4
	0.2	11.7	16.6	22.6	29.6	37.4	47.8
EVRA 40	0.1	14.5	19.8	26.3	34.8	43.3	52.8
	0.15	16.5	23.3	31.3	40.8	52.8	64.8
	0.2	18.3	26.0	35.3	46.3	58.5	74.8

R 404A

EVRAT 10	0.1	1.2	1.5	2.0	2.5	3.1	3.7
	0.15	1.4	1.8	2.4	3.1	3.8	4.6
	0.2	1.6	2.1	2.7	3.4	4.3	5.3
EVRAT 15	0.1	2.1	2.7	3.6	4.5	5.5	6.6
	0.15	2.5	3.3	4.3	5.5	6.8	8.2
	0.2	2.8	3.7	4.9	6.1	7.8	9.5
EVRAT 20	0.1	3.5	4.6	6.0	7.5	9.2	11.1
	0.15	4.1	5.5	7.1	9.2	11.3	13.6
	0.2	4.6	6.2	8.1	10.2	13.0	15.8
EVRA 25	0.1	7.7	10.1	13.3	16.6	20.4	24.6
	0.15	9.1	12.1	15.8	20.4	25.0	30.3
	0.2	10.3	13.8	18.0	22.7	28.8	35.0
EVRA 32	0.1	12.3	16.2	21.3	26.6	32.6	39.4
	0.15	14.6	19.4	25.3	32.6	40.0	48.5
	0.2	16.5	22.0	28.8	36.3	46.1	56.0
EVRA 40	0.1	19.3	25.3	33.3	41.5	51.0	61.5
	0.15	22.9	30.3	39.5	51.0	62.5	75.6
	0.2	25.8	34.5	45.0	56.8	72.1	87.5

Capacities are based on liquid temperature $t_l = +25^\circ\text{C}$ ahead of evaporator.
The table values refer to the evaporator capacity and are given as a function of evaporating temperature t_e and pressure drop Δp across valve.
Capacities are based on dry, saturated vapour ahead of valve. During operation with superheated vapour ahead of valve, the capacities are reduced by 4% for each 10 K superheat.

Correction factors

When sizing valves, the evaporator capacity must be multiplied by a correction factor depending on liquid temperature t_l ahead of expansion valve. When the corrected capacity is known, the selection can be made from the table.

t_l °C	-10	0	+10	+20	+25	+30	+40	+50
R 134a	0.76	0.81	0.88	0.96	1.0	1.05	1.16	1.31
R 404A	0.70	0.76	0.84	0.94	1.0	1.07	1.24	1.47

Capacity
(continued)

R 717 (NH₃)

 Hot gas capacity Q_h kW

Type	Pressure drop across valve Δp bar	Hot gas capacity Q_e kW				
		Evaporating temp. $t_e = -10^\circ\text{C}$. Hot gas temp. $t_h = t_c + 25^\circ\text{C}$. Subcooling $\Delta t_{\text{sub}} = 4\text{K}$				
		Condensing temperature t_c °C				
		+20	+30	+40	+50	+60
EVRA 3	0.1	1.8	2.1	2.3	2.5	2.6
	0.2	2.6	2.9	3.2	3.5	3.7
	0.4	3.8	4.2	4.6	4.9	5.3
	0.8	5.1	6.0	6.5	7.1	7.6
	1.6	7.4	8.3	9.1	9.9	10.9
EVRAT 10	0.1	12.0	13.4	14.7	16.0	17.2
	0.2	17.1	19.0	20.9	22.7	24.4
	0.4	24.5	27.1	29.7	32.2	34.7
	0.8	34.0	39.0	42.6	46.1	49.5
	1.6	48.5	53.8	59.1	64.3	71.3
EVRAT 15	0.1	21.7	24.1	26.4	28.8	31.0
	0.2	30.8	34.2	37.5	40.8	44.0
	0.4	44.1	48.8	53.5	58.0	62.4
	0.8	61.2	70.3	76.7	83.0	89.1
	1.6	87.4	96.9	106.0	116.0	128.0
EVRAT 20	0.1	36.1	40.1	44.0	48.0	51.7
	0.2	51.4	57.0	62.6	68.0	73.2
	0.4	73.5	81.3	89.1	96.7	104.0
	0.8	102.0	117.0	128.0	138.0	148.0
	1.6	146.0	161.0	177.0	193.0	214.0
EVRA 25	0.1	80.2	89.1	98.0	107.0	115.0
	0.2	114.0	127.0	139.0	151.0	163.0
	0.4	163.0	181.0	198.0	215.0	231.0
	0.8	227.0	260.0	284.0	307.0	330.0
	1.6	324.0	358.0	394.0	429.0	475.0
EVRA 32	0.1	128.0	143.0	157.0	171.0	184.0
	0.2	183.0	203.0	223.0	242.0	260.0
	0.4	261.0	289.0	317.0	344.0	370.0
	0.8	362.0	416.0	455.0	492.0	528.0
	1.6	518.0	574.0	631.0	688.0	761.0
EVRA 40	0.1	201.0	223.0	244.0	267.0	287.0
	0.2	286.0	317.0	348.0	378.0	407.0
	0.4	408.0	452.0	495.0	537.0	578.0
	0.8	566.0	650.0	710.0	769.0	825.0
	1.6	809.0	897.0	986.0	1074.0	1188.0

An increase in hot gas temperature t_h of 10 K, based on $t_h = t_c + 25^\circ\text{C}$, reduces valve capacity approx. 2% and vice versa.

A change in evaporating temperature t_e changes valve capacity; see correction factor table below.

Correction factor

When sizing valves, the table value must be multiplied by a correction factor depending on evaporating temperature t_e .

t_e °C	-40	-30	-20	-10	0	+10
R 717 (NH ₃)	0.89	0.91	0.96	1.0	1.06	1.10

Capacity
(continued)

R 22

Hot gas capacity Q_h kW

Type	Pressure drop across valve Δp bar	Hot gas capacity Q_h kW				
		Evaporating temp. $t_e = -10^\circ\text{C}$. Hot gas temp. $t_h = t_c + 25^\circ\text{C}$. Subcooling $\Delta t_{\text{sub}} = 4\text{K}$.				
		Condensing temperature t_c °C				
		+20	+30	+40	+50	+60
EVRA 3	0.1	0.68	0.72	0.76	0.78	0.79
	0.2	0.97	1.0	1.1	1.1	1.1
	0.4	1.4	1.5	1.5	1.6	1.6
	0.8	1.9	2.0	2.1	2.3	2.3
	1.6	2.7	2.9	3.0	3.1	3.2
EVRAT 10	0.1	4.4	4.7	4.9	5.1	5.2
	0.2	6.3	6.7	7.0	7.2	7.3
	0.4	9.0	9.6	10.0	10.3	10.4
	0.8	12.4	13.2	13.9	14.7	14.9
	1.6	17.5	18.6	19.6	20.2	20.5
EVRAT 15	0.1	8.0	8.5	8.9	9.2	9.3
	0.2	11.4	12.1	12.6	13.0	13.2
	0.4	16.3	17.2	18.0	18.5	18.7
	0.8	22.3	23.1	24.9	26.5	26.8
	1.6	31.5	33.5	35.2	36.4	36.9
EVRAT 20	0.1	13.3	14.1	14.8	15.3	15.5
	0.2	19.0	20.1	21.0	21.7	22.0
	0.4	27.1	28.7	30.0	30.9	31.2
	0.8	37.1	38.4	41.5	44.2	44.6
	1.6	52.5	55.9	58.6	60.6	61.5
EVRA 25	0.1	29.6	31.4	32.9	34.0	34.4
	0.2	42.1	44.6	46.7	48.2	48.8
	0.4	60.2	63.8	66.6	68.6	69.4
	0.8	82.5	87.9	92.3	98.2	99.2
	1.6	117.0	124.0	130.0	135.0	137.0
EVRA 32	0.1	47.4	50.2	52.6	54.4	55.0
	0.2	67.4	71.4	74.7	77.1	78.1
	0.4	96.3	102.0	107.0	110.0	111.0
	0.8	132.0	140.0	148.0	157.0	159.0
	1.6	187.0	199.0	209.0	216.0	219.0
EVRA 40	0.1	74.0	78.5	82.3	85.0	86.0
	0.2	105.0	112.0	117.0	121.0	122.0
	0.4	151.0	159.0	167.0	172.0	174.0
	0.8	206.0	222.0	231.0	246.0	248.0
	1.6	291.0	310.0	326.0	337.0	342.0

An increase in hot gas temperature t_h of 10 K, based on $t_h = t_c + 25^\circ\text{C}$, reduces valve capacity approx. 2% and vice versa.

A change in evaporating temperature t_e changes valve capacity; see correction factor table below.

Correction factor

When sizing valves, the table value must be multiplied by a correction factor depending on evaporating temperature t_e .

t_e °C	-40	-30	-20	-10	0	+10
R 22	0.90	0.94	0.97	1.0	1.03	1.05

R 134a

Capacity
(continued)

 Hot gas capacity Q_h kW

Type	Pressure drop across valve Δp bar	Hot gas capacity Q_g kW				
		Evaporating temp. $t_e = -10^\circ\text{C}$. Hot gas temp. $t_h = t_c + 25^\circ\text{C}$. Subcooling $\Delta t_{\text{sub}} = 4\text{K}$				
		Condensing temperature t_c °C				
		+20	+30	+40	+50	+60
EVRA 3	0.1	0.54	0.57	0.6	0.61	0.6
	0.2	0.77	0.82	0.85	0.86	0.85
	0.4	1.1	1.2	1.2	1.2	1.2
	0.8	1.5	1.6	1.7	1.8	1.8
	1.6	2.2	2.3	2.4	2.5	2.4
EVRAT 10	0.1	3.5	3.7	3.9	4.0	3.9
	0.2	5.0	5.3	5.5	5.6	5.6
	0.4	7.0	7.7	7.9	8.0	7.9
	0.8	9.9	10.5	11.0	11.6	11.4
	1.6	14.3	15.1	15.7	16.0	15.9
EVRAT 15	0.1	6.4	6.7	7.0	7.1	7.1
	0.2	9.1	9.6	10.0	10.1	10.0
	0.4	12.6	13.8	14.2	14.4	14.3
	0.8	17.9	19.0	19.8	20.8	20.5
	1.6	25.7	27.2	28.2	28.8	28.6
EVRAT 20	0.1	10.6	11.2	11.7	11.8	11.8
	0.2	15.1	16.0	16.6	16.8	16.7
	0.4	21.0	22.9	23.7	24.0	23.8
	0.8	29.8	31.6	33.0	34.7	34.2
	1.6	42.8	45.3	47.1	47.9	47.6
EVRA 25	0.1	23.6	24.9	25.9	26.4	26.2
	0.2	33.6	35.5	36.8	37.4	37.1
	0.4	46.6	51.0	52.7	53.4	52.9
	0.8	66.2	70.2	73.2	77.0	76.0
	1.6	95.2	101.0	105.0	107.0	106.0
EVRA 32	0.1	37.6	39.8	41.4	42.1	41.8
	0.2	53.8	56.8	58.9	59.8	59.4
	0.4	74.7	81.6	84.3	85.4	84.6
	0.8	106.0	112.0	117.0	123.0	122.0
	1.6	152.0	161.0	167.0	170.0	169.0
EVRA 40	0.1	58.8	62.3	64.7	65.8	65.3
	0.2	84.1	88.8	92.1	93.5	92.8
	0.4	117.0	127.0	132.0	134.0	132.0
	0.8	166.0	176.0	183.0	192.0	190.0
	1.6	238.0	252.0	262.0	266.0	265.0

An increase in hot gas temperature t_h of 10 K, based on $t_h = t_c + 25^\circ\text{C}$, reduces valve capacity approx. 2% and vice versa.

A change in evaporating temperature t_e changes valve capacity; see correction factor table below.

Correction factor

When sizing valves, the table value must be multiplied by a correction factor depending on evaporating temperature t_e .

t_e °C	-40	-30	-20	-10	0	+10
R 134a	0.88	0.92	0.98	1.0	1.04	1.08

Capacity
(continued)

R 404A

 Hot gas capacity Q_h kW

Type	Pressure drop across valve Δp bar	Hot gas capacity Q_h kW				
		Evaporating temp. $t_e = -10^\circ\text{C}$. Hot gas temp. $t_h = t_c + 25^\circ\text{C}$. Subcooling $\Delta t_{\text{sub}} = 4\text{K}$				
		Condensing temperature t_c °C				
		+20	+30	+40	+50	+60
EVRA 3	0.1	0.62	0.63	0.62	0.59	0.54
	0.2	0.87	0.89	0.88	0.83	0.76
	0.4	1.2	1.3	1.3	1.2	1.1
	0.8	1.7	1.7	1.7	1.7	1.5
	1.6	2.4	2.5	2.4	2.3	2.1
EVRAT 10	0.1	4.0	4.1	4.0	3.8	3.5
	0.2	5.7	5.8	5.7	5.5	5.0
	0.4	8.1	8.2	8.2	7.8	7.0
	0.8	11.1	11.4	11.3	11.1	10.1
	1.6	15.7	16.0	15.8	15.2	13.9
EVRAT 15	0.1	7.3	7.4	7.3	6.9	6.3
	0.2	10.2	10.4	10.3	9.8	8.9
	0.4	14.6	14.8	14.7	14.0	12.7
	0.8	20.1	20.4	20.3	20.0	18.1
	1.6	28.3	28.8	28.4	27.4	25.0
EVRAT 20	0.1	12.1	12.3	12.1	11.5	10.5
	0.2	17.1	17.3	17.2	16.3	14.9
	0.4	24.4	24.7	24.5	23.3	21.1
	0.8	33.4	34.0	33.9	33.3	30.2
	1.6	47.1	48.0	47.4	45.6	41.6
EVRA 25	0.1	26.8	27.4	26.9	25.6	23.3
	0.2	37.9	38.4	38.2	36.3	33.0
	0.4	54.2	54.9	54.5	51.7	47.0
	0.8	74.2	75.6	75.3	74.0	67.2
	1.6	105.0	107.0	105.0	101.0	92.5
EVRA 32	0.1	43.0	43.8	43.0	40.9	37.3
	0.2	60.6	61.4	61.1	58.1	52.8
	0.4	86.7	87.8	87.2	82.7	75.2
	0.8	119.0	121.0	120.0	118.0	107.0
	1.6	167.0	171.0	168.0	162.0	148.0
EVRA 40	0.1	67.0	68.5	67.3	64.0	58.3
	0.2	94.8	96.0	95.5	90.8	82.5
	0.4	136.0	137.0	136.0	129.0	117.0
	0.8	186.0	189.0	188.0	185.0	168.0
	1.6	262.0	266.0	263.0	253.0	231.0

An increase in hot gas temperature t_h of 10 K, based on $t_h = t_c + 25^\circ\text{C}$, reduces valve capacity approx. 2% and vice versa.

A change in evaporating temperature t_e changes valve capacity; see correction factor table below.

Correction factor

When sizing valves, the table value must be multiplied by a correction factor depending on evaporating temperature t_e .

t_e °C	-40	-30	-20	-10	0	+10
R 404A	0.86	0.88	0.93	1.0	1.03	1.07

Capacity
(continued)

 Hot gas capacity G_h kg/s

Type	Hot gas temperature t_h °C	Condensing temperature t_c °C	Hot gas capacity G_h kg/s at pressure drop across valve Δp bar							
			0.5	1	2	3	4	5	6	7

R 717 (NH₃)

EVRA 3	+90	+25	0.003	0.005	0.006	0.007	0.007	0.007	0.007	0.007	0.007	0.007
		+35	0.004	0.005	0.007	0.009	0.009	0.01	0.01	0.01	0.01	0.01
		+45	0.005	0.006	0.009	0.01	0.011	0.012	0.013	0.013	0.013	0.013
EVRA/T 10		+25	0.022	0.03	0.04	0.045	0.048	0.048	0.048	0.048	0.048	0.048
		+35	0.026	0.036	0.048	0.056	0.061	0.064	0.065	0.065	0.065	0.065
		+45	0.030	0.041	0.056	0.066	0.074	0.079	0.083	0.085	0.086	0.086
EVRA/T 15		+25	0.040	0.054	0.072	0.081	0.086	0.087	0.087	0.087	0.087	0.087
		+35	0.046	0.064	0.086	0.1	0.109	0.115	0.117	0.117	0.117	0.117
		+45	0.053	0.074	0.101	0.12	0.133	0.142	0.149	0.153	0.155	0.155
EVRA/T 20	+25	0.066	0.09	0.12	0.12	0.144	0.145	0.145	0.145	0.145	0.145	
	+35	0.077	0.107	0.144	0.167	0.182	0.191	0.195	0.195	0.195	0.195	
	+45	0.089	0.124	0.169	0.199	0.211	0.237	0.248	0.255	0.258	0.258	
EVRA 25	+25	0.143	0.197	0.26	0.296	0.313	0.316	0.316	0.316	0.316	0.316	
	+35	0.168	0.232	0.313	0.364	0.397	0.417	0.425	0.425	0.425	0.425	
	+45	0.194	0.269	0.368	0.434	0.482	0.516	1.54	0.555	0.561	0.561	
EVRA 32	+25	0.233	0.322	0.424	0.483	0.511	0.516					
	+35	0.274	0.379	0.511	0.594	0.648	0.681	0.694				
	+45	0.316	0.439	0.601	0.709	0.787	0.842	0.882	0.906	0.916		
EVRA 40	+25	0.362	0.503	0.663	0.755	0.798	0.806					
	+35	0.429	0.592	0.798	0.929	1.013	1.064	1.084				
	+45	0.495	0.686	0.939	1.107	1.23	1.316	1.378	1.416	1.431		

R 22

EVRA 3	+90	+25	0.008	0.011	0.014	0.016	0.017	0.017	0.017	0.017	0.017	0.017
		+35	0.009	0.012	0.017	0.019	0.021	0.022	0.022	0.022	0.022	0.022
		+45	0.010	0.014	0.019	0.022	0.025	0.026	0.027	0.028	0.028	0.028
EVRA/T 10		+25	0.051	0.069	0.092	0.104	0.109	0.111	0.111	0.111	0.111	0.111
		+35	0.058	0.08	0.108	0.125	0.136	0.142	0.144	0.144	0.144	0.144
		+45	0.066	0.092	0.125	0.146	0.162	0.172	0.179	0.183	0.183	0.183
EVRA/T 15		+25	0.091	0.125	0.165	0.187	0.197	0.199	0.199	0.199	0.199	0.199
		+35	0.105	0.144	0.194	0.225	0.244	0.256	0.258	0.258	0.258	0.258
		+45	0.119	0.165	0.224	0.263	0.291	0.31	0.322	0.329	0.330	0.330
EVRA/T 20	+25	0.152	0.208	0.275	0.311	0.328	0.332	0.332	0.332	0.332	0.332	
	+35	0.174	0.241	0.323	0.375	0.407	0.425	0.431	0.431	0.431	0.431	
	+45	0.193	0.275	0.374	0.439	0.485	0.516	0.537	0.548	0.55	0.55	
EVRA 25	+25	0.331	0.453	0.599	0.677	0.715	0.722	0.722	0.722	0.722	0.722	
	+35	0.38	0.524	0.704	0.816	0.886	0.925	0.938	0.938	0.938	0.938	
	+45	0.431	0.598	0.814	0.956	1.056	1.125	1.169	1.192	1.197	1.197	
EVRA 32	+25	0.539	0.739	0.976	1.106	1.168	1.179					
	+35	0.619	0.856	1.15	1.331	1.446	1.509	1.531				
	+45	0.704	0.978	1.329	1.562	1.723	1.837	1.909	1.947	1.955		
EVRA 40	+25	0.843	1.155	1.525	1.728	1.825	1.843					
	+35	0.968	1.338	1.798	2.08	2.26	2.358	2.393				
	+45	1.1	1.528	2.078	2.44	2.693	2.87	2.383	3.043	3.055		

An increase in hot gas temperature t_h of 10 K reduces valve capacity approx. 2% and vice versa.

Capacity
(continued)

Hot gas capacity G_h kg/s

Type	Hot gas temperature t_h °C	Condensing temperature t_c °C	Hot gas capacity G_h kg/s at pressure drop across valve Δp bar									
			0.5	1	2	3	4	5	6	7	8	
R 134a												
EVRA 3	+60	+25	0.007	0.009	0.011	0.012	0.012	0.016	0.016	0.021	0.021	0.021
		+35	0.009	0.011	0.014	0.016	0.016	0.021	0.021	0.021	0.021	0.021
		+45	0.01	0.012	0.018	0.02	0.021	0.021	0.021	0.021	0.021	0.021
EVRAT 10		+25	0.048	0.06	0.074	0.077	0.077	0.104	0.104	0.135	0.135	0.135
		+35	0.055	0.071	0.092	0.103	0.104	0.135	0.135	0.135	0.135	0.135
		+45	0.06	0.084	0.111	0.127	0.134	0.135	0.135	0.135	0.135	0.135
EVRAT 15		+25	0.081	0.108	0.134	0.14	0.14	0.187	0.187	0.244	0.244	0.244
		+35	0.094	0.129	0.166	0.192	0.187	0.244	0.244	0.244	0.244	0.244
		+45	0.108	0.151	0.2	0.228	0.241	0.244	0.244	0.244	0.244	0.244
EVRAT 20		+25	0.134	0.18	0.223	0.233	0.233	0.312	0.312	0.407	0.407	0.407
		+35	0.157	0.215	0.276	0.307	0.312	0.407	0.407	0.407	0.407	0.407
		+45	0.181	0.252	0.333	0.381	0.403	0.407	0.407	0.407	0.407	0.407
EVRA 25		+25	0.292	0.391	0.486	0.506	0.506	0.679	0.679	0.885	0.885	0.885
		+35	0.341	0.467	0.602	0.668	0.679	0.885	0.885	0.885	0.885	0.885
		+45	0.393	0.549	0.725	0.83	0.876	0.885	0.885	0.885	0.885	0.885
EVRA 32		+25	0.478	0.638	0.793	1.826	0.826	1.108	1.108	1.446	1.446	1.446
		+35	0.556	0.763	0.994	1.091	1.108	1.446	1.446	1.446	1.446	1.446
		+45	0.641	0.897	1.197	1.354	1.432	1.446	1.446	1.446	1.446	1.446
EVRA 40		+25	0.747	0.998	1.24	1.291	1.291	1.731	1.731	2.259	2.259	2.259
		+35	0.87	1.192	1.553	1.704	1.731	2.259	2.259	2.259	2.259	2.259
		+45	1.002	1.402	1.87	2.117	2.237	2.259	2.259	2.259	2.259	2.259

R 404A

EVRA 3	+60	+25	0.01	0.013	0.018	0.021	0.022	0.023	0.023	0.023	0.023
		+35	0.011	0.015	0.02	0.024	0.027	0.028	0.029	0.029	0.03
		+45	0.012	0.017	0.023	0.028	0.032	0.034	0.035	0.036	0.037
EVRAT 10		+25	0.063	0.087	0.116	0.134	0.145	0.148	0.149	0.149	0.149
		+35	0.072	0.1	0.134	0.158	0.174	0.184	0.19	0.19	0.192
		+45	0.081	0.112	0.153	0.182	0.203	0.228	0.228	0.237	0.239
EVRAT 15		+25	0.113	0.157	0.21	0.242	0.26	0.267	0.269	0.269	0.269
		+35	0.129	0.18	0.242	0.285	0.313	0.332	0.341	0.342	0.346
		+45	0.146	0.202	0.275	0.327	0.365	0.393	0.411	0.424	0.431
EVRAT 20		+25	0.189	0.262	0.35	0.403	0.433	0.445	0.449	0.449	0.449
		+35	0.215	0.3	0.404	0.474	0.521	0.552	0.569	0.57	0.576
		+45	0.243	0.337	0.459	0.545	0.609	0.656	0.684	0.707	0.719
EVRA 25		+25	0.411	0.57	0.763	0.878	0.942	0.969	0.978	0.978	0.978
		+35	0.468	0.653	0.881	1.032	1.136	1.203	1.239	1.241	1.253
		+45	0.529	0.734	1.0	1.188	1.326	1.43	1.49	1.539	1.566
EVRA 32		+25	0.672	0.931	1.245	1.432	1.539	1.581	1.581	1.581	1.581
		+35	0.765	1.069	1.436	1.686	1.854	1.964	2.022	2.025	2.025
		+45	0.862	1.198	1.632	1.939	1.836	2.34	2.433	2.513	2.557
EVRA 40		+25	1.05	1.454	1.946	2.238	2.406	2.471	2.471	2.471	2.471
		+35	1.195	1.657	2.245	2.635	2.897	3.068	3.161	3.166	3.166
		+45	1.348	1.873	2.55	3.03	3.384	3.65	3.801	3.926	3.995

An increase in hot gas temperature t_h of 10 K reduces valve capacity approx. 2% and vice versa.

**Design
Function**

- 4. Coil
- 16. Armature
- 18. Valve plate / Pilot valve plate
- 20. Earth terminal
- 24. Connection for flexible steel hose
- 28. Gasket
- 29. Pilot orifice
- 30. O-ring
- 31. Piston ring
- 36. DIN plug
- 40. Terminal box
- 43. Valve cover
- 44. O-ring
- 45. Valve cover gasket
- 48. Flange gasket
- 49. Valve body
- 51. Cover / Threaded plug
- 53. Manual operation spindle
- 59. Strainer
- 73. Equalization hole
- 74. Main channel
- 75. Pilot channel
- 76. Compression spring
- 80. Diaphragm/Servo piston
- 82. Support washer
- 83. Valve seat
- 84. Main valve plate

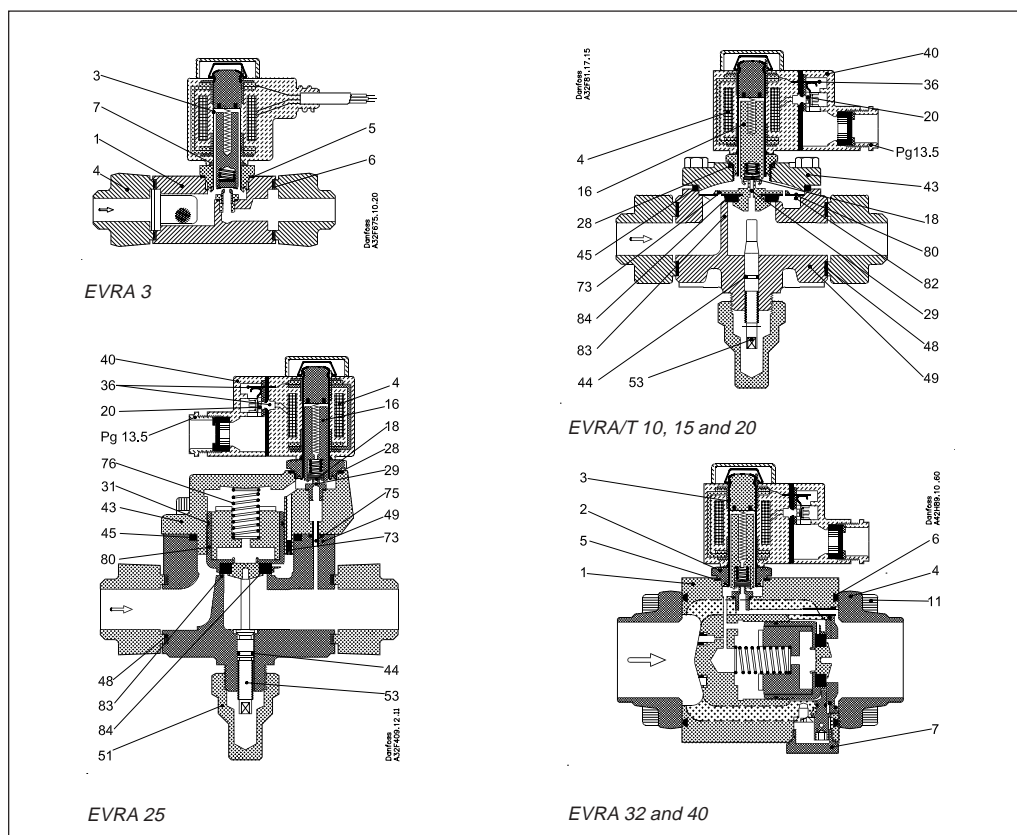

EVRA solenoid valves are designed on two different principles:

1. Direct operation
2. Servo operation

1. Direct operation

EVRA 3 is direct operated. The valve opens direct for full flow when the armature (16) moves up into the magnetic field of the coil. This means that the valve operates with a min. differential pressure of 0 bar.

The teflon valve plate (18) is fitted direct on the armature (16).

Inlet pressure acts from above on the armature and the valve plate. Thus, inlet pressure, spring force and the weight of the armature act to close the valve when the coil is currentless.

2. Servo operation

EVRA/T 10 → 20 are servo operated with a "floating" diaphragm (80). The pilot orifice (29) of stainless steel is placed in the centre of the diaphragm. The teflon pilot valve plate (18) is fitted direct to the armature (16).

When the coil is currentless, the main orifice and pilot orifice are closed. The pilot orifice and main orifice are held closed by the weight of the armature, the armature spring force and the differential pressure between inlet and outlet sides.

When current is applied to the coil the armature is drawn up into the magnetic field and opens the pilot orifice. This relieves the pressure above the diaphragm, i.e. the space above the diaphragm becomes connected to the outlet side of the valve. The differential pressure between inlet and outlet sides then presses the diaphragm away from the main orifice and opens it for full flow. Therefore a certain minimum differential pressure is necessary to open the valve and keep it open. For EVRA/T 10 → 20 valves this differential pressure is 0.05 bar.

When current is switched off, the pilot orifice closes. Via the equalization holes (73) in the diaphragm, the pressure above the diaphragm then rises to the same value as the inlet pressure and the diaphragm closes the main orifice.

EVRA 25, 32 and 40 are servo operated piston valves. The valves are closed with currentless coil.

The servo piston (80) with main valve plate (84) closes against the valve seat (83) by means of the differential pressure between inlet and outlet side of the valve, the force of the compression spring (76) and possibly the piston weight. When current to the coil is switched on, the pilot orifice (29) opens. This relieves the pressure on the piston spring side of the valve. The differential pressure will then open the valve. The minimum differential pressure needed for full opening of the valves is 0.07 bar.

Material specification

EVRA3

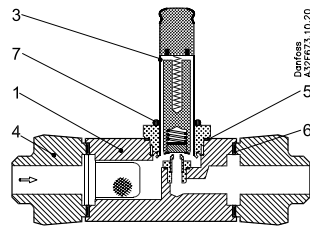

EVRAT 10/15/20

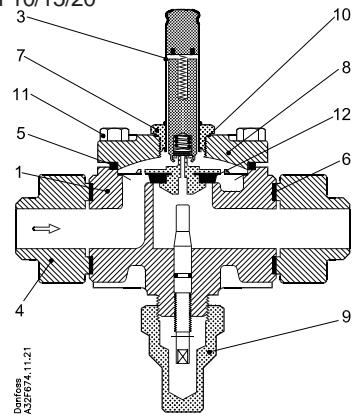

No.	Description	Solenoid valves					Standard	
		Type	Material	Analysis	Mat.no.	W.no.	ISO	EN
1	Valve body	EVRA 3	Free-cutting steel	11MnPb30				10277-3
		EVRAT 10/15/20	Cast-iron	GJS-400-18-LT				1563
3	Armature tube	EVRA 3/10/15/20	Stainless steel	X2CrNi19-11				10088
4	Flange	EVRA 3	Steel	S235JRG2				10025
5	Gasket	EVRA 3	Rubber	CR				
6	Gasket	EVRA 3	asbestos-free					
7	Armature tube nut	EVRAT 10/15/20	Stainless steel	X8CrNiS18-9				10088
8	Cover	EVRAT 10/15/20	Cast-iron	GJS-400-18-LT				1563
9	Cover/ thread plug	EVRAT 10/15/20	Free-cutting steel	11SMnPb30				10277-3
10	Gasket	EVRAT 10/15/20	Aluminium	Al 99.5				10210
11	Bolts	EVRA 3	Stainless steel	A2-70			3506	
		EVRAT 10/15/20	Stainless steel					
12	Valve seat	EVRAT 10/15/20	Teflon (PTFE)					

EVRA 25

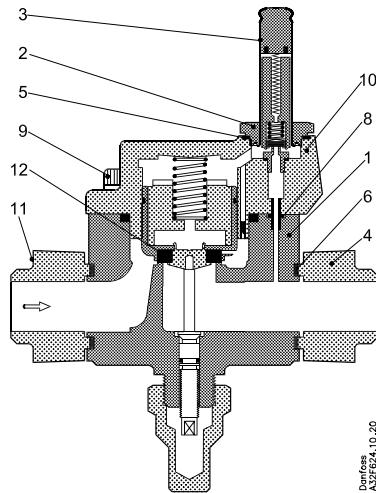

EVRA 32/40

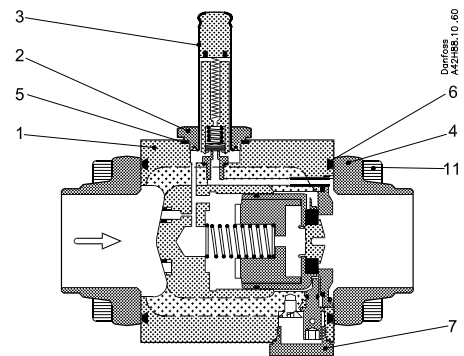

No.	Description	Solenoid valves					Standard	
		Type	Material	Analysis	Mat.no.	W.no.	ISO	EN
1	Valve body	EVRA 25/32/40	Cast-iron	GJS-400-18-LT				10025
2	Armature tube nut	EVRA 25/32/40	Stainless steel	X8CrNiS18-9				10088
3	Armature tube	EVRA 25/32/40	Stainless steel	X2CrNi19-11				10088
4	Flange	EVRA 25	Steel	S235JRG2				10025
		EVRA 32/40	Steel	P285QH				10222-4
5	Gasket	EVRA 32/40	Aluminium	Al 99.5				10210
6	Gasket	EVRA 25/32/40	Rubber	CR				
7	Cover/ thread plug	EVRA 25	Free-cutting steel	11SMnPb30				10277-3
		EVRA 32/40	Stainless steel	X5CrNi17-10				10088
8	Gasket	EVRA 25	Rubber	CR				
9	Bolts	EVRA 25	Stainless steel	A2-70			5306	
10	Cover	EVRA 25	Cast-iron	GJS-400-18-LT				10222-4
11	Bolts	EVRA 25/32/40	Stainless steel	A2-70			5306	
12	Valve seat	EVRA						

Dimensions and weight

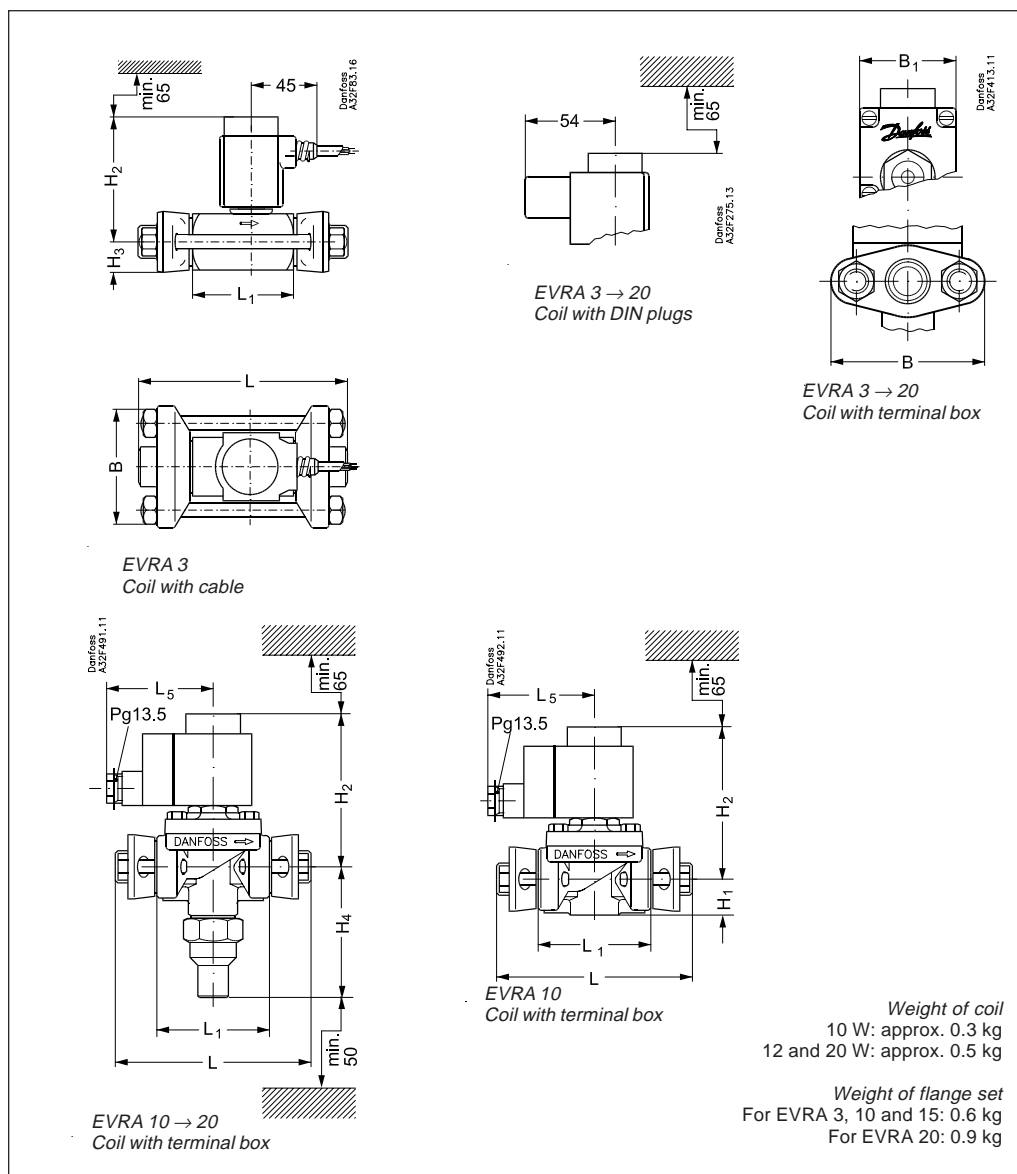

Type	H_1 mm	H_2 mm	H_3 mm	H_4 mm	L mm	L_1 mm	L_5 max.		B mm	B_1 max. mm	Weight ¹⁾ kg
							10 W	12 W 20 W			
							mm	mm			
EVRA 3		84	19		124	65	75	85	80	68	1.2
EVRA/T 10	22	100		81	130	68			80	68	1.7
EVRA/T 15		100		81	130	68			80	68	1.8
EVRA/T 20		110		77	155	85			96	68	2.7

¹⁾ With coil, without flanges

Dimension and weight
(continued)

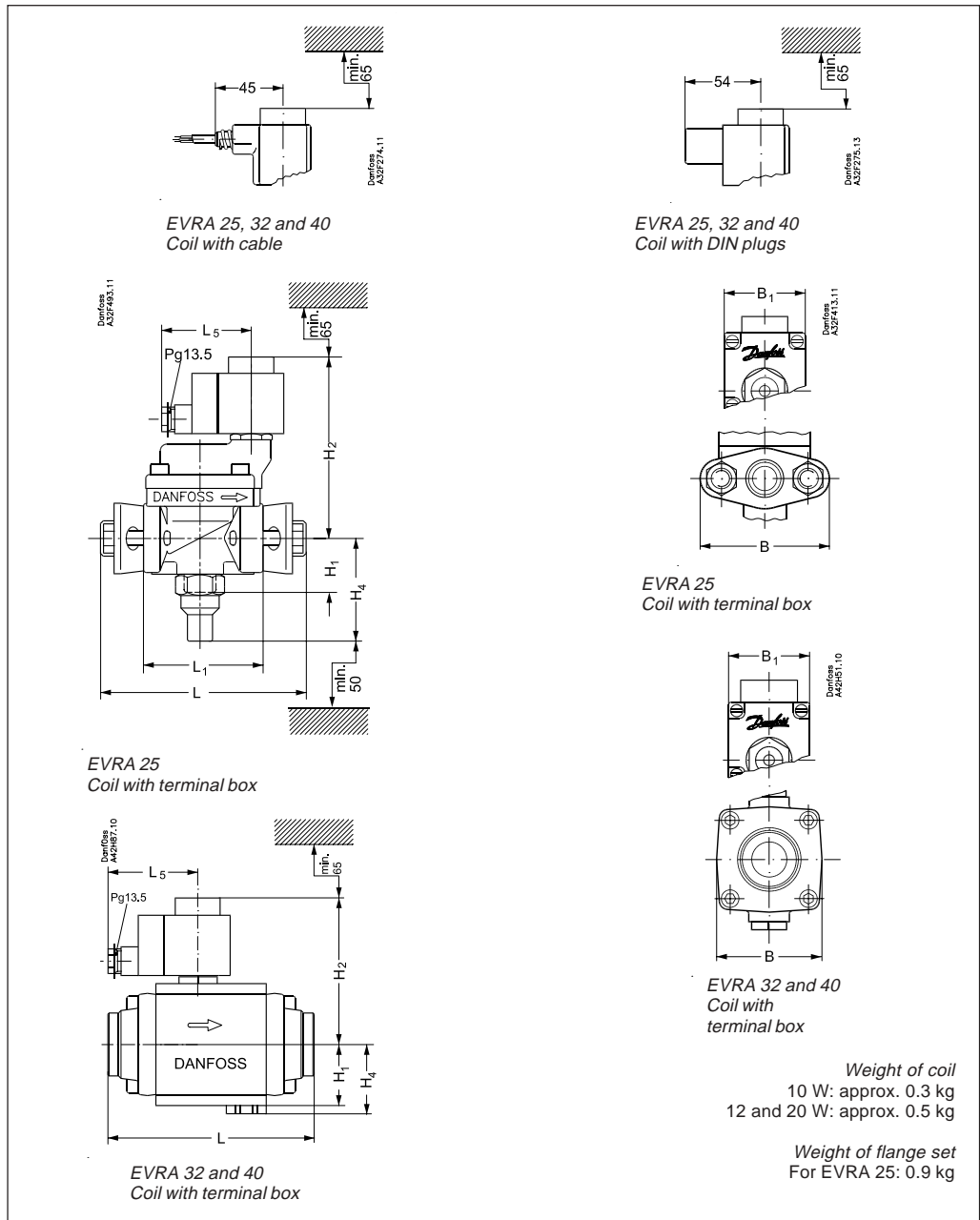

Type	H ₁	H ₂	H ₃	H ₄	L	L ₁	L ₅ max.		B	B ₁ max.	Weight ¹⁾
							10 W	12 W 20 W			
	mm	mm	mm	mm	mm	mm	mm	mm	mm	mm	kg
EVRA 25	46	141		78	162	92			95	68	3.0
EVRA 32	47	115		53	175		75	85	80	68	4.0
EVRA 40	47	115		53	175				80	68	4.0

¹⁾ With coil, without flanges

Danfoss can accept no responsibility for possible errors in catalogues, brochures and other printed material. Danfoss reserves the right to alter its products without notice. This also applies to products already on order provided that such alterations can be made without consequential changes being necessary in specifications already agreed. All trademarks in this material are property of the respective companies. Danfoss and the Danfoss logotype are trademarks of Danfoss A/S. All rights reserved.

