

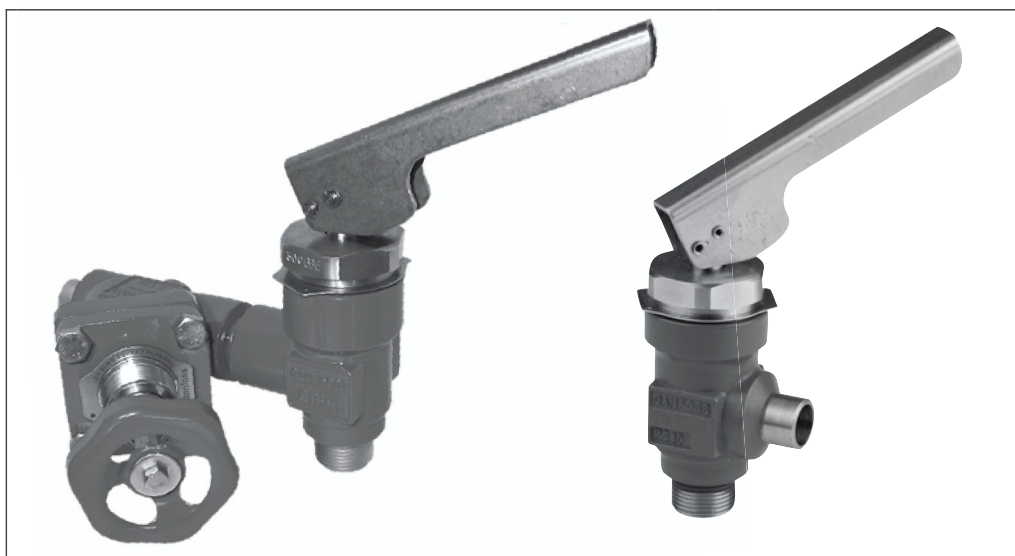

Quick closing oil drain valve, type QDV 15

Introduction



QDV is a quick closing oil drain valve, designed particularly for draining oil from systems containing refrigerant (ammonia) under pressure. The valve will close immediately on release of the handle, thus protecting user and environment against unnecessary refrigerant leaks. The valve should as a rule be installed as illustrated in fig. 1. In order to prevent hydraulic pressure building up

between the stop valve and the QDV an integral relief device is included as part of the cone arrangement, which will open at approx. 25 bar g (363 psig).

QDV is designed to meet the safety demands specified by national and international authorities within industrial refrigeration.

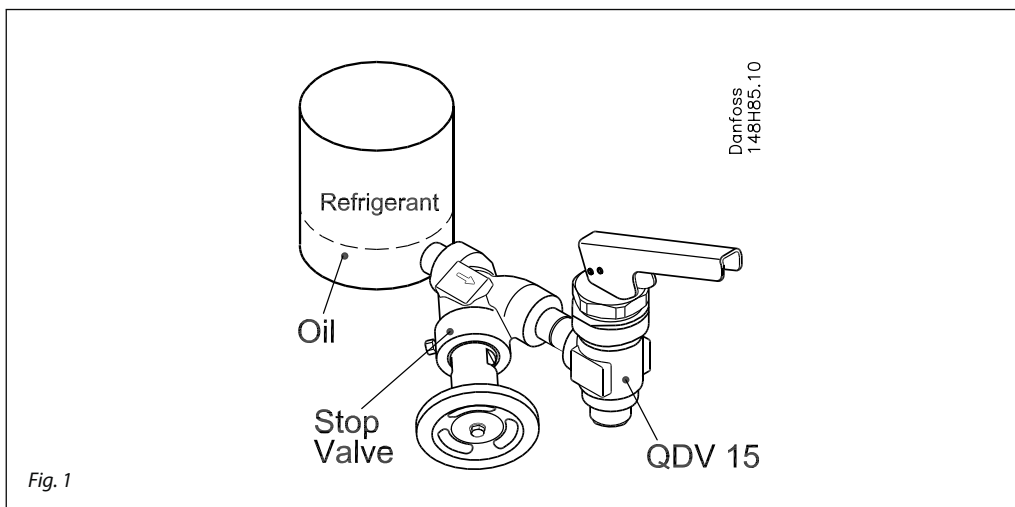

Fig. 1

Features

- QDV is generally used with R717 (ammonia) but the valve is also applicable to all other common non flammable refrigerants and non corrosive gases/liquids dependent on sealing material compatibility
- Meets the safety demands within industrial refrigeration
- Handle can be positioned 360°
- Built-in integral relief device opening over 25 bar g (preventing hydraulic pressure building up between stop valve and QDV).
- Can be supplied together with a stop valve for quick on site mounting
- Max. operating pressure: 40 bar g (580 psi g).
- Temperature range: -50/+150°C (-58/+302°F).
- Classification: To get an updated list of certification on the products please contact your local Danfoss Sales Company.

Design*Connections*

Available with the following connections:

- Inlet: Welding DIN (EN 10220)
 - ½ in. FPT
 - ¾ in. FPT
- Outlet: G ¾ in. pipe thread (ISO 228/1)
 - ½ in. FPT
 - ¾ in. FPT

Optional extras for outlet:

- Welding nipple DIN (EN 10220)
- Hose connection

Other types of connection are available on request.

QDV - SVA combinations

Combinations of the QDV together with a dedicated SVA have been established for easy selection. Please study page 6 to find the code numbers for these combinations.

Installation

For further information refer to installation instruction for QDV.

Technical data

- Refrigerants
QDV is generally used with R717 (ammonia) but the valve is also applicable to all other common non flammable refrigerants and non corrosive gases/liquids dependent on sealing material compatibility.
- QDV is a backpressure dependent valve. If any tube or hose is mounted on the outlet of the QDV it has to be calculated to prevent backpressure building up when relieving.
- For further information please see installation instruction for QDV.
Flammable hydrocarbons are not recommended, for further information please contact your local Danfoss Sales Company.
- Temperature range
-50/+150°C (-58/+302°F).
- Pressure
The valve is designed for:
Maximum operating pressure of 40 bar g (580 psi g)

Material specification

QDV 15

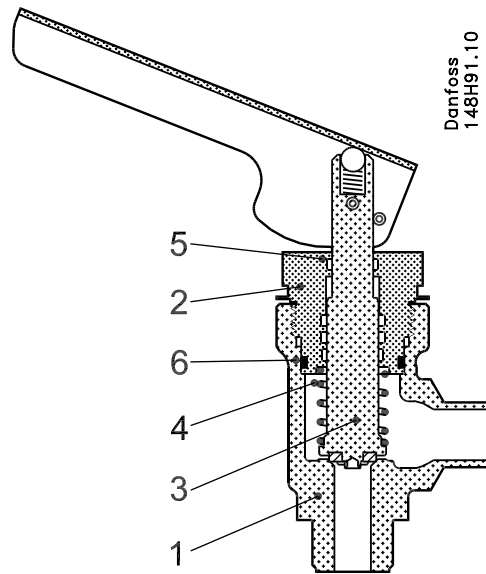

No.	Part	Material	DIN/EN	ISO	ASTM
1	Housing	Steel	G20Mn5QT EN10213-3		LCC A352
2	Bonnet	Stainless steel X110CrNi	S189 17440	Type 17 683/13	AISI 303
3	Spindle/Cone	Stainless steel X110CrNi	S189 17440	Type 17 683/13	AISI 303
4	Spring	Steel	11SMn30	Type 2	Grade 1213
5	Wear ring		EN10087	R683/9	A29
6	O-ring	Cloroprene			

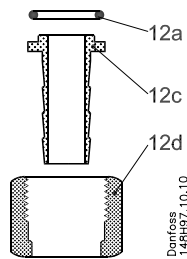

Hose connection for outlet

No.	Part	Material
12a	O-rings	Cloroprene (Neoprene)
12c	Stub for hose	Steel
12d	Union nut	Steel

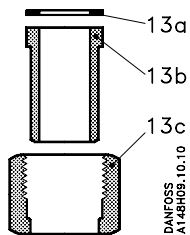

Welding nipple connection for outlet

No.	Part	Material
13a	Al-packing	Aluminium
13b	Welding nipple	Steel
13c	Union nut	Steel

Connections

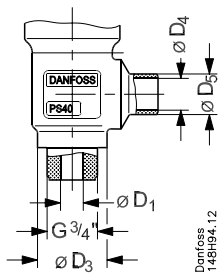

		ØD ₁	ØD ₃	ØD ₄	ØD ₅
QDV 15 DIN 15	mm	12	36.5	16.7	21.3
	in.	0.47	1.44	0.66	0.84

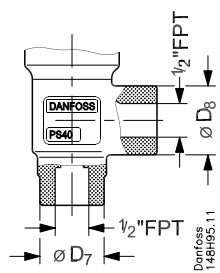

		ØD ₇	ØD ₈
QDV 15 1/2" FPT	mm	34	36.5
	in.	1.34	1.44

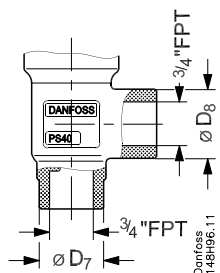

		ØD ₇	ØD ₈
QDV 15 3/4" FPT	mm	34	36.5
	in.	1.34	1.44

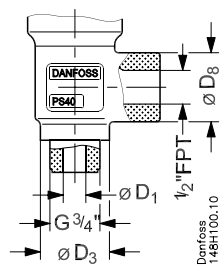

		ØD ₁	ØD ₃	ØD ₈
QDV 15 DIN 15	mm	12	36.5	34
	in.	0.47	1.44	1.34

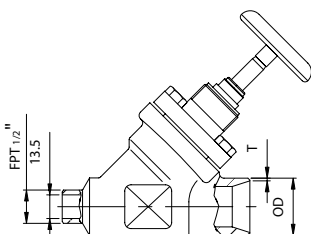

		OD	T	k _v -straight m ³ /h	C _v -straight USgal/min
SVA-ST DIN 15	mm	21.3	2.3	4.9	5.7
	in.	0.839	0.091		

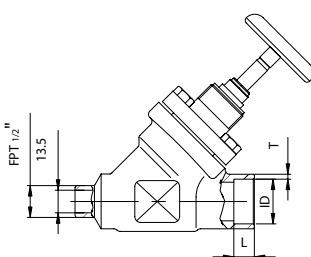

		ID	T	L	k _v -straight m ³ /h	C _v -straight USgal/min
SVA-ST SOC 1/2 in.	mm	21.8	6.0	10	4.9	5.7
	in.	0.858	0.235	0.39		

Dimensions

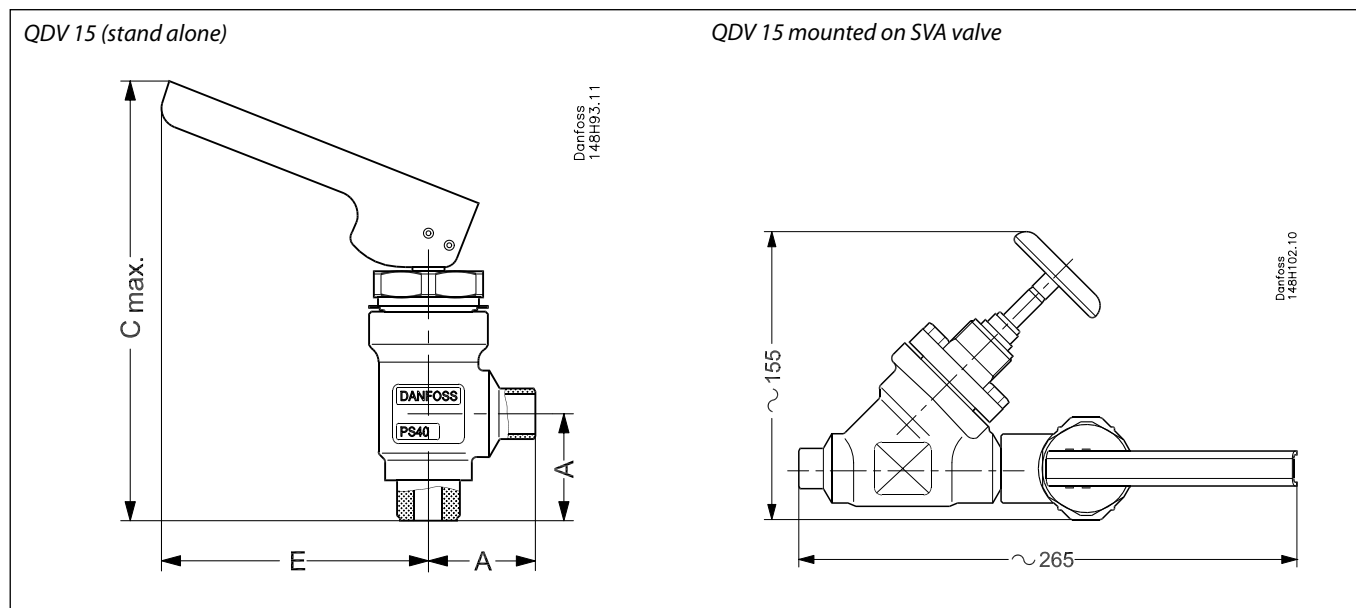

Valve size		A	C _{max}	E
QDV 15	mm	45	185	109
	in.	1.77	7.28	4.29

Ordering

How to order

The table below is used to identify the valve required.

Type	Inlet	Outlet	Code no.
QDV 15 DN 15	DN 15	G ¾ in.	148H3272
QDV 15 ½ in. FPT	½ in. FPT	½ in. FPT	148H3273
QDV 15 ¾ in. FPT	¾ in. FPT	¾ in. FPT	148H3274
QDV 15 DN 15 + SVA-ST DN 15 H-WHEEL*	DN 15	G ¾ in.	148H3310
QDV 15 ½ in. FPT + SVA-ST SOC ½ in. H-WHEEL*	½ in. SOC	½ in. FPT	148H3311
Fittings for hose connection			2469+065
Fittings for welding connection			2469+066

* Two valves are supplied in one box and should be mounted on site.
The indicated inlet is for the stop valve - The indicated outlet is for the oil drain valve.

Important!

Where products need to be certified according to specific certification societies or where higher pressures are required, the relevant information should be included at the time of order.