

Technical leaflet

Stop valves
type SVA 6 - 10



Contents

Page

Introduction	3
Features	3
Design	4
Technical data	4
Material specification	5
Connections	6
Dimensions and weights	7
SVA 6 -10 in angle execution with handwheel (SVA 121)	7
SVA 6 - 10 in angle execution with cap (SVA 123)	7
SVA 6 - 10 in angle execution with cap and extended bonnet (SVA 126)	7
SVA 6 - 10 in straight-way execution with handwheel (SVA 221)	8
SVA 6 - 10 in straight-way execution with cap (SVA 223)	8
SVA 6 - 10 in straight-way execution with cap and extended bonnet (SVA 226)	8
SVA 6 - 10 angle valve in nipple execution with handwheel (SVA 121)	9
SVA 6 - 10 angle valve in nipple execution with cap (SVA 123)	9
SVA 6 - 10 angle valve in nipple execution with extended bonnet and with cap (SVA 126) ...	9
Ordering	10

Introduction



SVA are angle-way and straight-way stop valves. The valves have internal backseating enabling the spindle seal to be replaced with the valve still under pressure. They are furthermore carefully designed to give favourable flow conditions. Easy to disassemble for inspection and repair, if

necessary. The valve cone is designed to ensure perfect closing.

SVA are available with the following optional equipment:

- With handwheel - for frequent operation.
- With vented cap - for infrequent operation.

Features

- Applicable to all common non flammable refrigerants including R 717 and non corrosive gases/liquids dependent on sealing material compatability.
- Optional accessories:
 - Handwheel for frequent operation
 - Vented cap for infrequent operation
- Designed to give favourable flow conditions.
- Internal backseating enables replacement of the spindle seal whilst the valve is active, i.e. under pressure
- Easy to disassemble for inspection and possible repair
- No special flow direction required for stop valves type SVA
- Max. operating pressure: 40 bar g (580 psi g) (valves for higher operating pressure available on request)
- Compact and light valves for easy handling and installation
- Classification: To get an updated list of certification on the products please contact your local Danfoss Sales Company.

Design
Connections

Available with the following connections:

- Welding DIN (2448)
- Welding ANSI (B 36.10 Schedule 80)
- Outside pipe thread, T (ISO 228/1)
- Welding nipples, NA (ANSI B 31.5 Schedule 80)
- Welding nipples, ND (DIN 2448)

Housing

Made of special, cold resistant steel approved for low temperature operations.

Valve cone

The valve cone can be turned on the spindle, and so there will be no friction between the cone and the seat, when the valve is opened and closed. Teflon tightening ring renders perfect sealing at a minimum closing momentum.

Spindle

Made of polished stainless steel, which is ideal for O-ring sealing.

Packing gland

The "full temperature range" packing gland ensures a perfect tightness in the whole range: $-50/+150^{\circ}\text{C}$ ($-58/+302^{\circ}\text{F}$). The packing glands are equipped with a scraper ring to prevent penetration of dirt and ice into the packing gland.

Installation

No special flow direction is required. The valve is designed to withstand high internal pressure. However, the piping system in general should be designed to avoid liquid traps and reduce the risk of hydraulic pressure caused by thermal expansion.

For further information refer to installation instructions.

Technical data

- Refrigerants
Applicable to all common non flammable refrigerants including R 717 and non corrosive gases/liquids dependent on sealing material compatibility. For further information please see installation instruction. Flammable hydrocarbons are not recommended. For further information please contact your local Danfoss Sales Company.

- Temperature Range
 $-50/+150^{\circ}\text{C}$ ($-58/+302^{\circ}\text{F}$).
- Pressure Range
The valves are designed for:
Max. working pressure: 40 bar g, (580 psi g).
Strength test: 80 bar g (1160 psi g).
Leakage test: 40 bar g (580 psi g).
Valves for higher working pressure are available on request.

Material specification

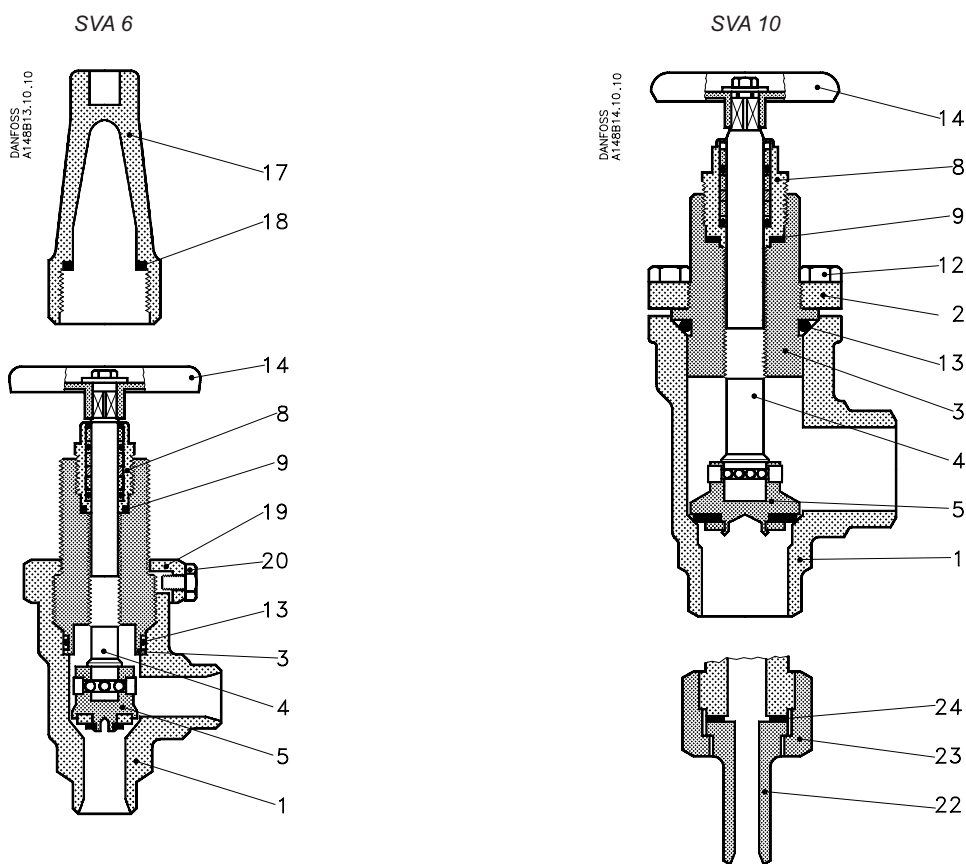

No.	Part	Material	DIN	ISO	ASTM
1	Housing	Steel	TTSSt 35N 17173	TW6 2604/3	Grade 1 A 333, A 334 A 350 LF2*
2	Bonnet, Flange	Steel	TTSSt 35N 17173	TW6 2604/3	Grade 1 A 333, A 334 A 350 LF2*
3	Bonnet, Insert	Steel	9S Mn28 1651	Type 2 R 683/9	1213 SAE J 403
4	Spindle	Stainless steel	X10CrNiS189 17440	Type 17 683/13	AISI 303
5	Cone	Steel	9S Mn28 1651	Type 2 R 683/9	1213 SAE J 403
8	Packing gland O-ring	Steel Cloroprene (Neoprene)			
9	Packing washer	Non-asbestos			
12	Bolts	Steel	Quality 8.8	Quality 8.8	Grade 5
13	O-ring	Cloroprene (Neoprene)			
14	Handwheel	Steel			
17	Cap	Aluminium			
18	Gasket f. cap	Nylon			
19	Locking nut	Steel			
20	Screw	Steel			
22	Welding nipple	Steel	RSt 37.2, 17100	Fe260B, 630	Grade C, A 283
23	Nut	Steel	9SMn28, 1651	Type 2, R 683/9	1213, SAEJ 403
24	Packing washer	Non-asbestos			

* Alternative material

Connections

Size		OD	T	OD	T			k _v -angle	k _v -straight	C _v -angle	C _v -straight
mm	in.	mm	mm	in.	in.			m ³ /h	m ³ /h	USgal/min	USgal/min

DIN

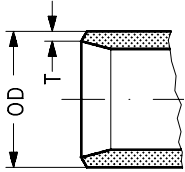

Welding DIN (2448)

6	1/4	13.5	2.3	0.531	0.091			2.9	2.0	3.4	2.4
10	3/8	17.2	2.3	0.677	0.091			4.5	3.2	5.2	3.6

ANSI

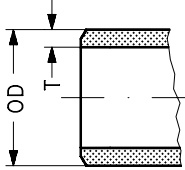

Welding ANSI (B 36.10 Schedule 80)

6	1/4	13.5	3.0	0.531	0.118			2.9	2.03	3.4	2.4
10	3/8	17.2	3.2	0.677	0.126			4.5	3.15	5.2	3.6

Size		Outside pipe thread		L	L	k _v -angle		C _v -angle	
mm	in.			mm	in.	m ³ /h		USgal/min	

T outside pipe thread, (ISO 228/1)

6	1/4	G 1/2		16	0.63	2.5		2.9	
---	-----	-------	--	----	------	-----	--	-----	--

T

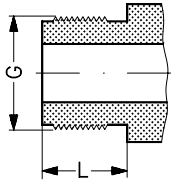

Nipples for T outside pipe thread (ISO 228/1)

Size		OD	T	OD	T	L	L				
mm	in.	mm	mm	in.	in.	mm	in.				

ND

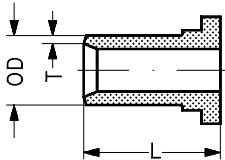

ND welding nipples, (DIN 2448)

6	1/4	13.5	2.3	0.531	0.091	60	2.36				
10	3/8	17.2	2.3	0.677	0.091	50	1.97				

NA

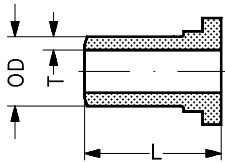

NA welding nipples, ANSI (B 36.10 Schedule 80)

6	1/4	13.5	3.0	0.531	0.118	60	2.36				
10	3/8	17.2	3.2	0.677	0.126	50	1.97				

Dimensions and weights

SVA 6 - 10 in angle execution with handwheel (SVA 121)

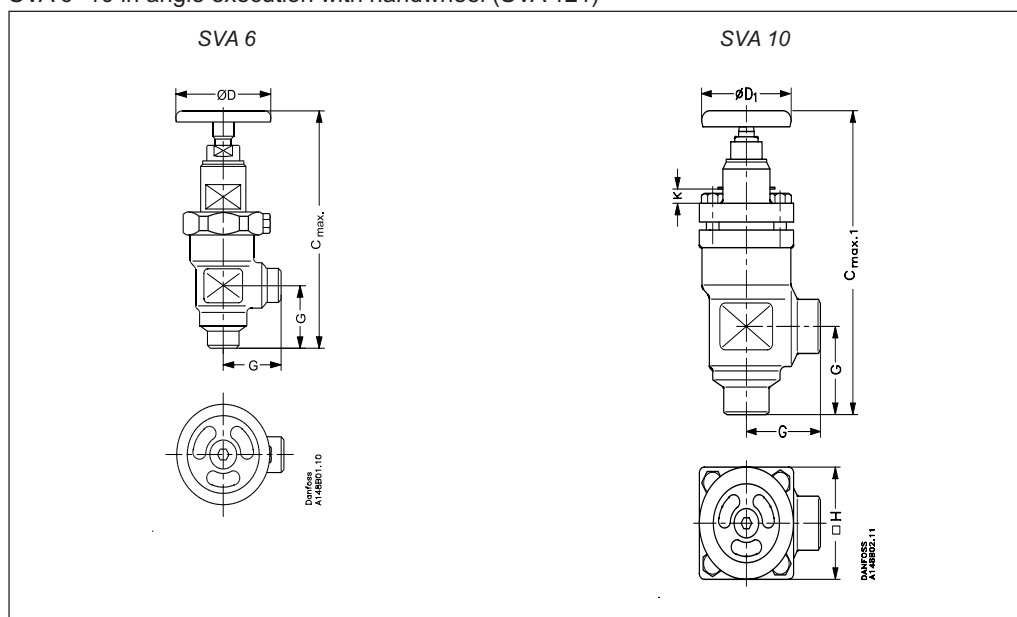

Valve size		C _{max.}	G	ØD	□H	Weight
SVA 6	mm in.	128 5.04	30 1.18	50 1.97		0.7 kg
SVA 10	mm in.	173 6.81	45 1.77	60 2.36	60 2.36	1.4 kg

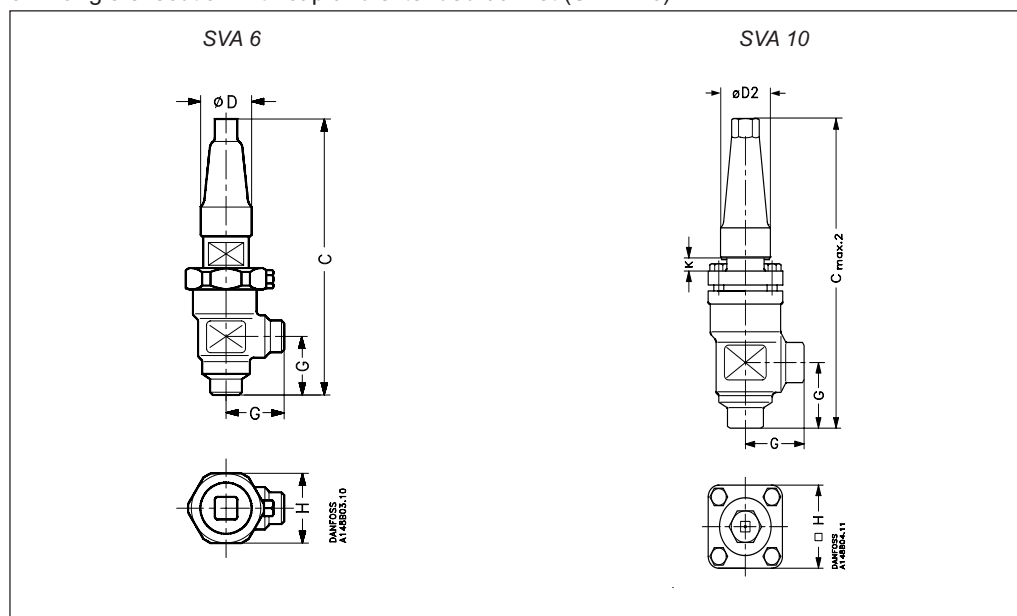
 SVA 6 - 10 in angle execution with cap (SVA 123)
 or in angle execution with cap and extended bonnet (SVA 126)

Valve size		C	G	ØD	□H	Weight
SVA 6	mm in.	139 5.47	30 1.18	30 1.18	48 1.89	0.8 kg
SVA 10	mm in.	182 7.17	45 1.77	38 1.50	60 2.36	1.4 kg

Specified weights are approximate values only.

Dimensions and weights

SVA 6 - 10 in straight-way execution with handwheel (SVA 221)

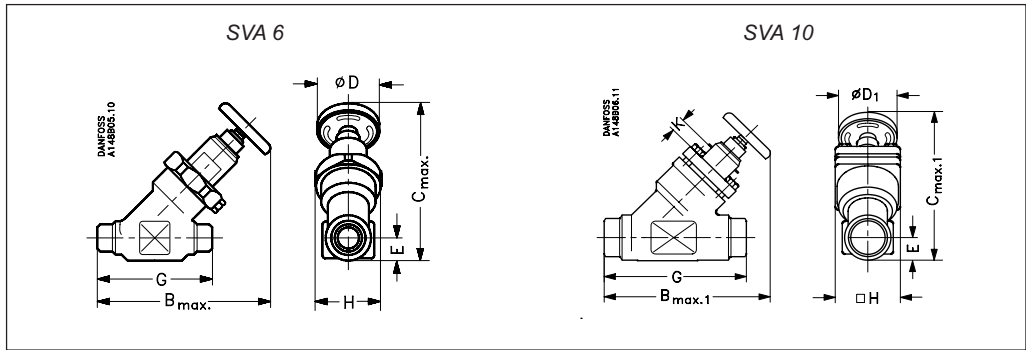

Valve size		C _{max.}	B _{max.}	E	G	ØD	□H	Weight
SVA 6	mm in.	110 4.33	120 4.72	13 0.49	70 2.76	50 1.97	48 1.89	0.7 kg
SVA 10	mm in.	145 5.71	160 6.30	20 0.79	120 4.72	60 2.36	60 2.36	2.0 kg

SVA 6 - 10 in straight-way execution with cap (SVA 223)
or in straight-way execution with cap and extended bonnet (SVA 226)

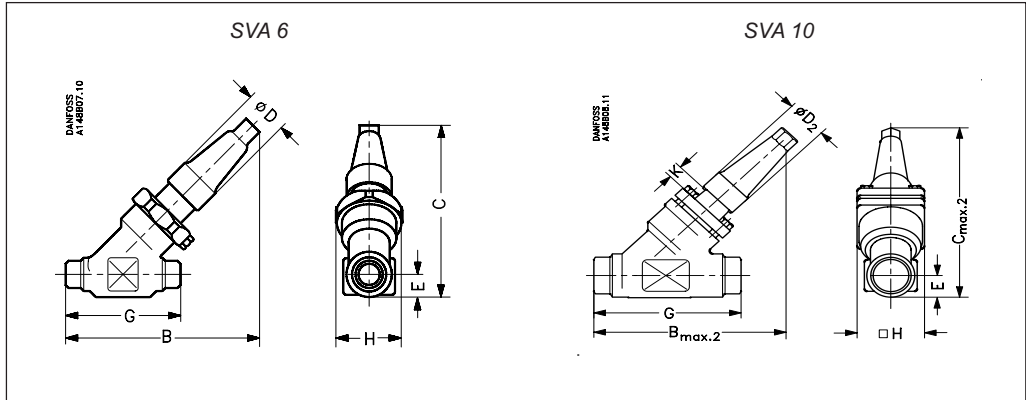

Valve size		C	B	E	G	ØD	□H	Weight
SVA 6	mm in.	110 4.33	120 4.72	13 0.49	70 2.76	30 1.16	48 1.89	0.8 kg
SVA 10	mm in.	145 5.71	155 6.10	20 0.79	120 4.72	38 1.50	60 2.36	2.0 kg

Specified weights are approximate values only.

Dimensions and weights

SVA 6 - 10 angle valve in nipple execution with handwheel (SVA 121)

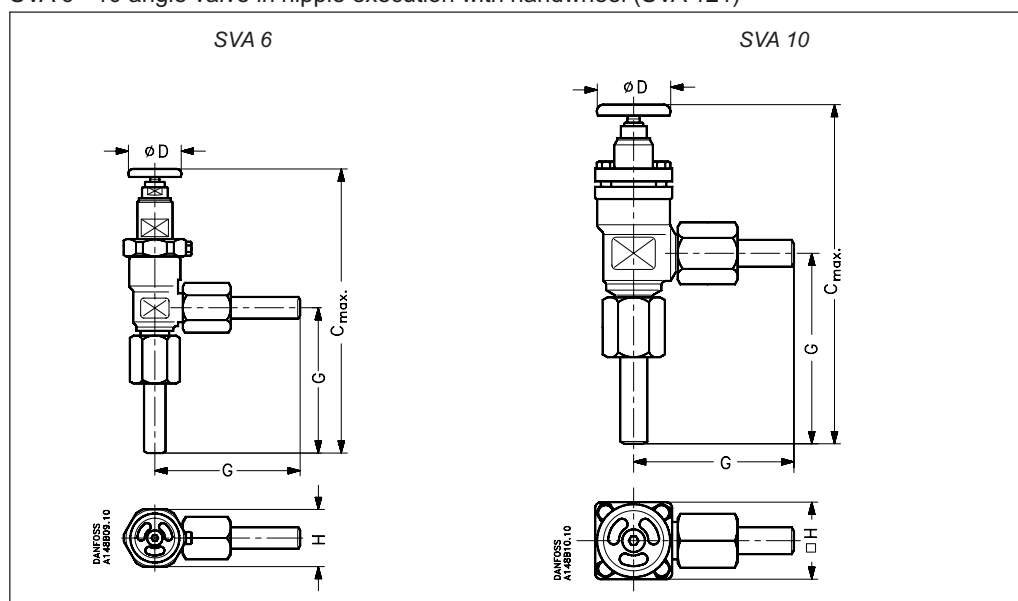

Valve size		C_{max}	G	$\varnothing D$	$\square H$	Weight
------------	--	-----------	---	-----------------	-------------	--------

SVA 6	mm in.	190 7.46	92 3.60	50 1.97		1.1 kg
SVA 10	mm in.	225 8.84	97 3.80	60 2.36	60 2.36	1.4 kg

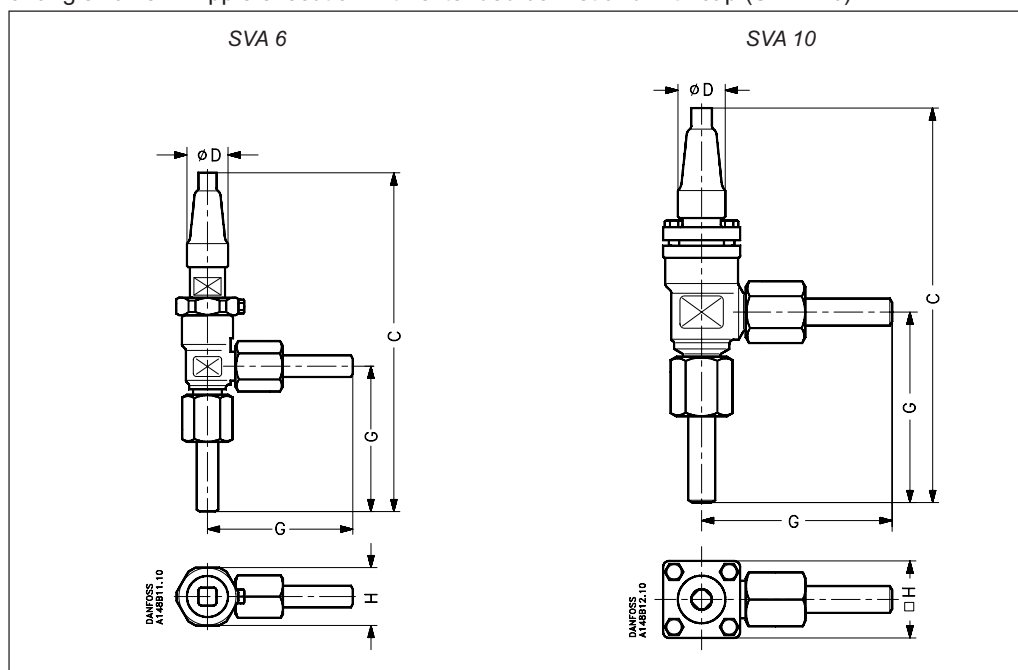
 SVA 6 - 10 angle valve in nipple execution with cap (SVA 123)
 or angle valve in nipple execution with extended bonnet and with cap (SVA 126)

Valve size		C	G	$\varnothing D$	$\square H$	Weight
------------	--	---	---	-----------------	-------------	--------

SVA 6	mm in.	201 7.89	92 3.60	30 1.16	48 1.89	1.2 kg
SVA 10	mm in.	234 9.19	97 3.80	38 1.55	60 2.36	1.4 kg

Specified weights are approximate values only.

Ordering

How to order

The table below is used to identify the valve required.

Please note that the type codes only serve to identify the valves, some of which may not form part of the standard product range. For further information please contact your local Danfoss Sales Company.

Example for type codes

SVA 10 D 1 2 1

Type codes

Valve type	SVA	Stop Valve												
Nominal size in mm (valve size measured on the connection diameter)	6 10	<table border="1"> <thead> <tr> <th colspan="3">Available connections</th> </tr> <tr> <th>A/D</th> <th>T</th> <th>NA/ND</th> </tr> </thead> <tbody> <tr> <td>DN 6</td> <td>x</td> <td>x</td> </tr> <tr> <td>DN 10</td> <td>x</td> <td>x</td> </tr> </tbody> </table>	Available connections			A/D	T	NA/ND	DN 6	x	x	DN 10	x	x
Available connections														
A/D	T	NA/ND												
DN 6	x	x												
DN 10	x	x												
Connections	A D T NA ND	Welding branches: ANSI B 36.10 schedule 80 Welding branches: DIN 2448 Outside threaded connections: ISO 228/1 Pipe thread Welding nipples: ANSI B 31.5 schedule 80 Welding nipples: DIN 2448												
Valve housing	1 2	Angle flow Straight flow (not T, NA, and ND connections)												
Materials	2	Housing: TT St 35N, Bonnet: TT St 35N/9SMn 28												
Other equipment	1 3 6	Handwheel, short spindle with Chloroprene (Neoprene) O-ring Cap, short spindle with Chloroprene (Neoprene) O-ring Cap and extended bonnet												

Important!

Where products need to be certified according to specific certification societies or where higher pressures are required, the relevant information should be included at the time of order.

Ordering
 (cont.)

 Angle flow
 With welding branches - DIN

Size		Type	Code Number
mm	in.		
6	1/4	SVA 6 D 121	2412+308
6	1/4	SVA 6 D 123	2412+315
10	3/8	SVA 10 D 121	2412+309
10	3/8	SVA 10 D 123	2412+316

 Straight flow
 With welding branches - DIN

Size		Type	Code Number
mm	in.		
6	1/4	SVA 6 D 221	2412+329
6	1/4	SVA 6 D 223	2412+336
10	3/8	SVA 10 D 221	2412+330
10	3/8	SVA 10 D 223	2412+337

 Angle flow
 With welding branches - ANSI

Size		Type	Code Number
mm	in.		
6	1/4	SVA 6 A 121	2412+350
6	1/4	SVA 6 A 123	2412+357
10	3/8	SVA 10 A 121	2412+351
10	3/8	SVA 10 A 123	2412+358

 Straight flow
 With welding branches - ANSI

Size		Type	Code Number
mm	in.		
6	1/4	SVA 6 A 221	2412+371
6	1/4	SVA 6 A 223	2412+378
10	3/8	SVA 10 A 221	2412+372
10	3/8	SVA 10 A 223	2412+379

 Angle flow
 With outside threaded connections - T

Size		Type	Code Number
mm	in.		
6	1/4	SVA 6 T 121	2413+123
6	1/4	SVA 6 T 123	2413+125

 Angle flow
 With welding nipples - ND

Size		Type	Code Number
mm	in.		
6	1/4	SVA 6 ND 121	2413+129
6	1/4	SVA 6 ND 123	2413+132
10	3/8	SVA 10 ND 121	2413+130
10	3/8	SVA 10 ND 123	2413+133
10	3/8	SVA 10 ND 126	2413+136

 Angle flow
 With welding nipples - NA

Size		Type	Code Number
mm	in.		
6	1/4	SVA 6 NA 121	2413+138
6	1/4	SVA 6 NA 123	2413+141
10	3/8	SVA 10 NA 121	2413+139
10	3/8	SVA 10 NA 123	2413+142
10	3/8	SVA 10 NA 126	2413+145