

Bombas de Óleo RSH Danfoss

Oil Pump Type RSH

Size 32, 63, 95, 125



General Data Sheet

For specific information on this product, please contact Danfoss Burner Components

Identification

RSH 63 (Example)

32	Capacity 91 l/h
63	Capacity 143 l/h
95	Capacity 210 l/h
125	Capacity 285 l/h

Capacity at 20 cSt., 15 bar, 2800 min⁻¹.

Note!

Shaft rotation, location of pressure outlet and other connections are seen from shaft end.

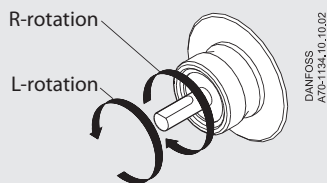

Connections

Example shows L-rotation pump. On R-rotating pumps location of connections are identical.

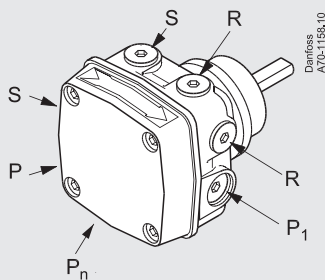

P ₁	Pressure adjustment
S	Suction inlet G 1/4
R	Return outlet G 1/4
P	Pressure outlet G 1/4
P _n	Pressure gauge port G 1/8
H	Filter

RSH oil pumps are designed for small/ medium sized domestic and commercial oil burners up to 285 l/h. The pumps have a built-in pressure regulator with shut-off function. A special regulation spring is available for feed/transfer applications.

Application and Features

- Light and heavy oil
- 1 or 2-pipe operation
- 1-stage
- Built-in pressure regulator with shut-off
- Ring filter
- Spec. spring available for feed/transfer applications

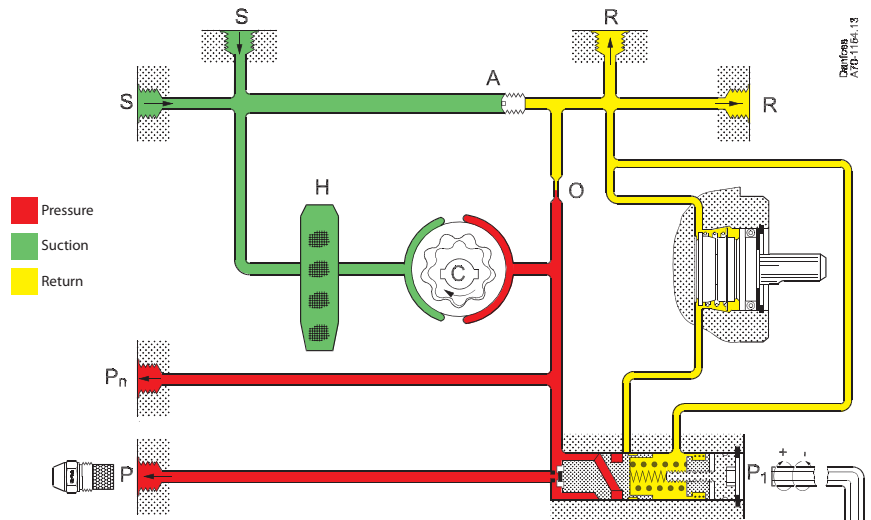

Function

From the suction inlet (S) oil is drawn through the gear set, where the pressure is increased. By means of the piston and the spring in the pressure regulator the pressure is kept constant at the value set on adjustment screw (P₁).

In 2-pipe systems the excess oil is led back to the return outlet (R). In 1-pipe systems with plugged return outlet (R) and removed by-pass screw (A), the oil is returned internally to the gear set (see details in below figure). When the pump is stopped the pressure drops and the spring force in the pressure regulator will move the piston until it seats and the oil flow is shut off effectively.

Changeover between 1 and 2-pipe operation. Filter change

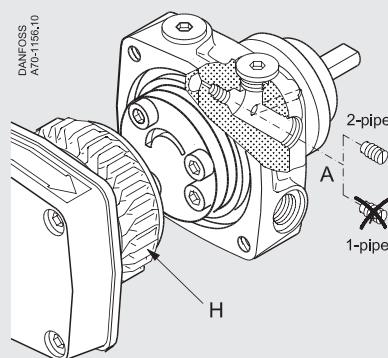

2-pipe: Screw (A) fitted 1-pipe: Screw (A) removed

Bleeding

In 2-pipe systems the pumps are self-priming, i.e. bleeding is performed via the constriction (O) to the return outlet (R).

In 1-pipe systems with plugged return outlet (R) and by-pass screw (A) removed, bleeding must be performed through the pressure gauge port (P_n).

In 1-pipe systems with underlying tank, the closing function of the regulating valve must be rendered inoperative. This is made by connecting the nozzle line to the pressure gauge port (P_n) and plug the pressure port (P). In this application a cut-off valve must be installed in the nozzle line.

Warranty

For pumps used outside the stated technical data and used with oil containing abrasive particles Danfoss cannot give any warranty.

Technical Data

RSH	Size	32	63	95	125
Viscosity range (measured in suction inlet)	cSt. (mm ² /s)	4.3 - 200			
Filter area/mesh	cm ² /μm	75/340	170/340		
Pressure range	bar	15-35			
Factory setting	bar	21 ±1			
Max. Pressure in suction inlet/return outlet	bar	4			
Speed	min ⁻¹	1400-3450			
Max. starting torque	Nm	0.22	0.25	0.30	0.35
Ambient temperature	°C	-20 to +120			
Storage temperature	°C	-25 to +120			
Temperature of medium	°C	-10 to +120			
Neck/Flange		EN 225			

Nozzle capacity

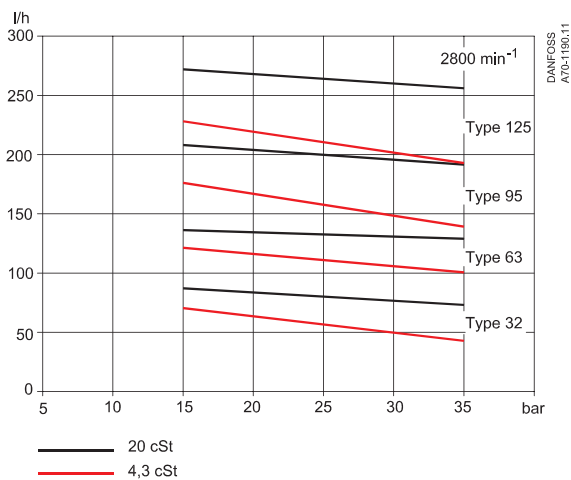

Operating torque

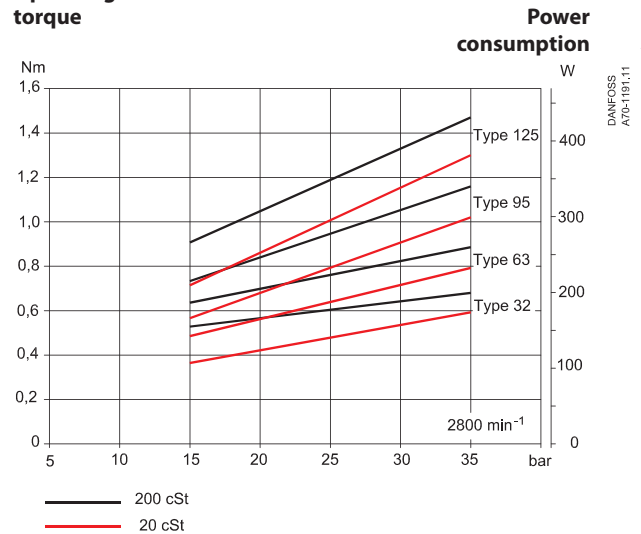

Dimensions

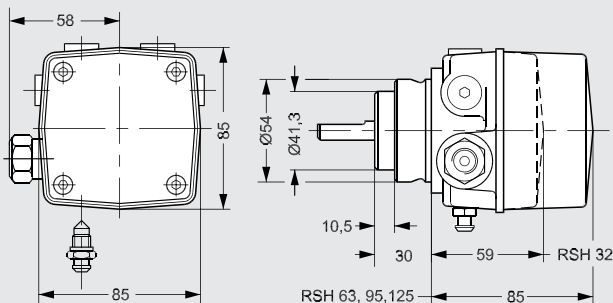

DANFOSS A70-1183.12

TYPE	L	L
RSH 32	28,8	60,8
RSH 63	26,8	58,8
RSH 95	-	62,0
RSH 125	30,0	62,0